

XANTENER BERICHTE

Band 25

DIE CAPITOLSINSULA
DER COLONIA ULPIA TRAIANA

Siedlungsgeschichtliche Entwicklung

Gundolf Precht

BEILAGEN

Eine Veröffentlichung des

Landschaftsverbandes Rheinland

LVR-Archäologischer Park Xanten / LVR-RömerMuseum

Inhalt

TEXT

Teil 1 Der Grabungsbereich an der Südost-Ecke der Insula 26

Teil 2 Die Grabungsbereiche an der Süd-, West-, Nord- und Nordost-Ecke der Insula 26

BEILAGEN

Beilage 1	Vorrömische Befunde
Beilage 2	Befunde der Periode 1a–b
Beilage 3	Befunde der Periode 2
Beilage 4	Befunde der Periode 3
Beilage 5	Befunde der Periode 4
Beilage 6	Befunde der Periode 5
Beilage 7	Befunde der Perioden 6, 8 und 9
Beilage 8	Befunde der Südwestecke von Insula 26
Beilage 9	Befunde der Westseite von Insula 26
Beilage 10	Befunde der Periode 7: Apsidenbau
Beilage 11	Befunde in den Schnitten 95/1.2, 97/11, 98/3 und Befunde des Ofens 2
Beilage 12	Befunde im Schnitt 2002/3.4
Beilage 13	Befunde in den Schnitten 95/4.5.7.19.20
Beilage 14	Lage der Hauptprofile und der Profile im Apsidenbau. – Legende zu den Grundrissen und Profilen.
Beilage 15	Profile 1 und 2
Beilage 16	Profile 3–7
Beilage 17	Profile 8–10
Beilage 18	Profile 11–17
Beilage 19	Profile 18–22
Beilage 20	Profile 23–25
Beilage 21	Profile 26–29
Beilage 22	Profile 30–34
Beilage 23	Profile 35–39
Beilage 24	Profile 40–46
Beilage 25	Profile 47–54

Textband und Beilagenband
Bibliografische Informationen der Deutschen Bibliothek

Die Deutsche Bibliothek verzeichnet diese Publikation in der Deutschen Nationalbibliografie;
detaillierte bibliografische Daten sind im Internet über <http://dnb.ddb.de> abrufbar.

ISBN 978-3-8053-4746-4

Gedruckt mit Unterstützung
des Ministeriums für Bauen, Wohnen, Stadtentwicklung und Verkehr
des Landes Nordrhein-Westfalen

Ministerium für Bauen, Wohnen,
Stadtentwicklung und Verkehr
des Landes Nordrhein-Westfalen



LVR-Archäologischer Park Xanten
LVR-RömerMuseum **APX**



Alle Rechte vorbehalten
Copyright Landschaftsverband Rheinland
LVR-Archäologischer Park Xanten / LVR-RömerMuseum 2013
Redaktion und Satz: www.wisa-print.de
Druck: DCM Druck Center Meckenheim GmbH
Printed in Germany



VERLAG PHILIPP VON ZABERN · DARMSTADT / MAINZ





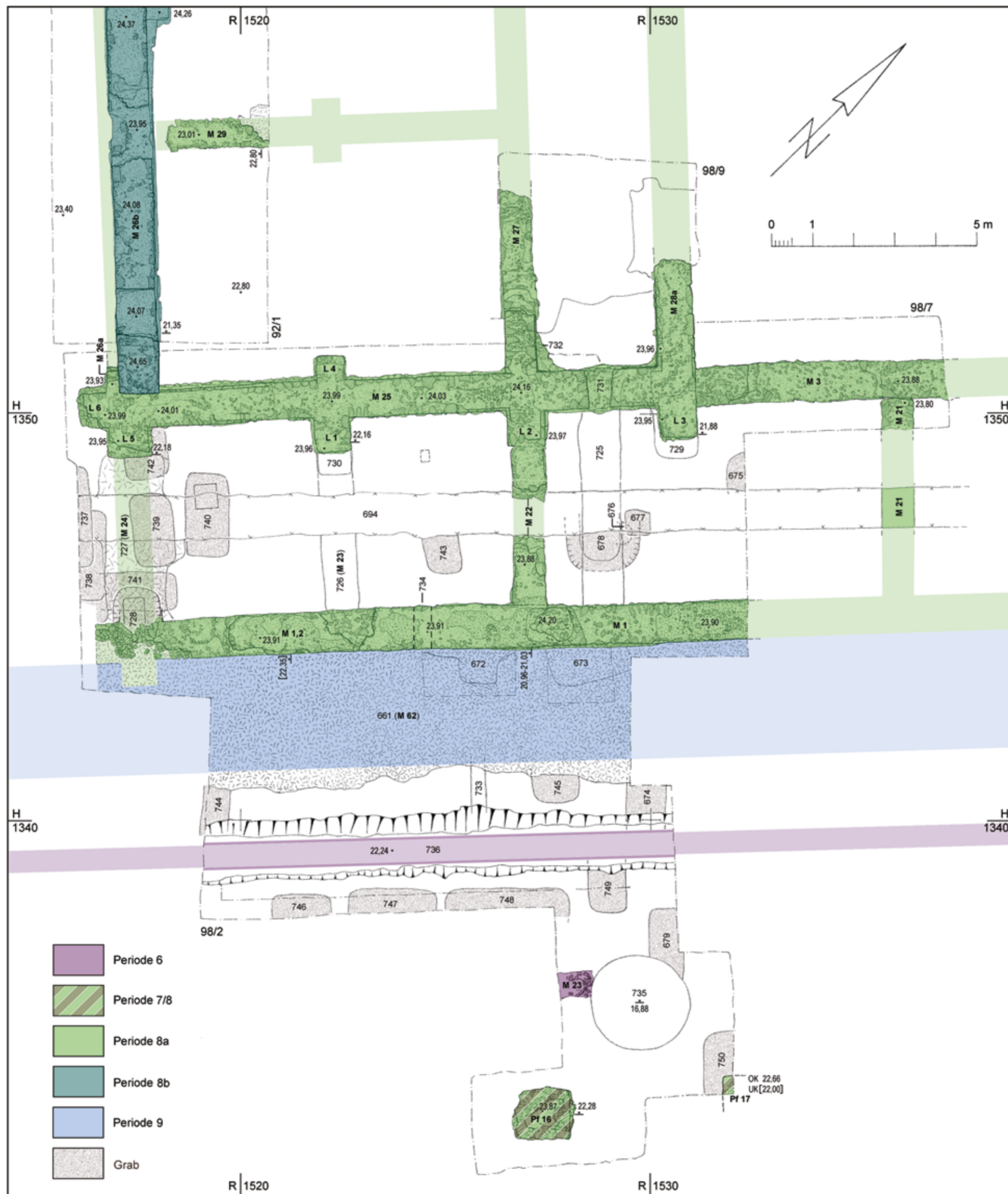

Beilage 8 Befunde der Südwestecke von Insula 26. – M. 1 : 100.

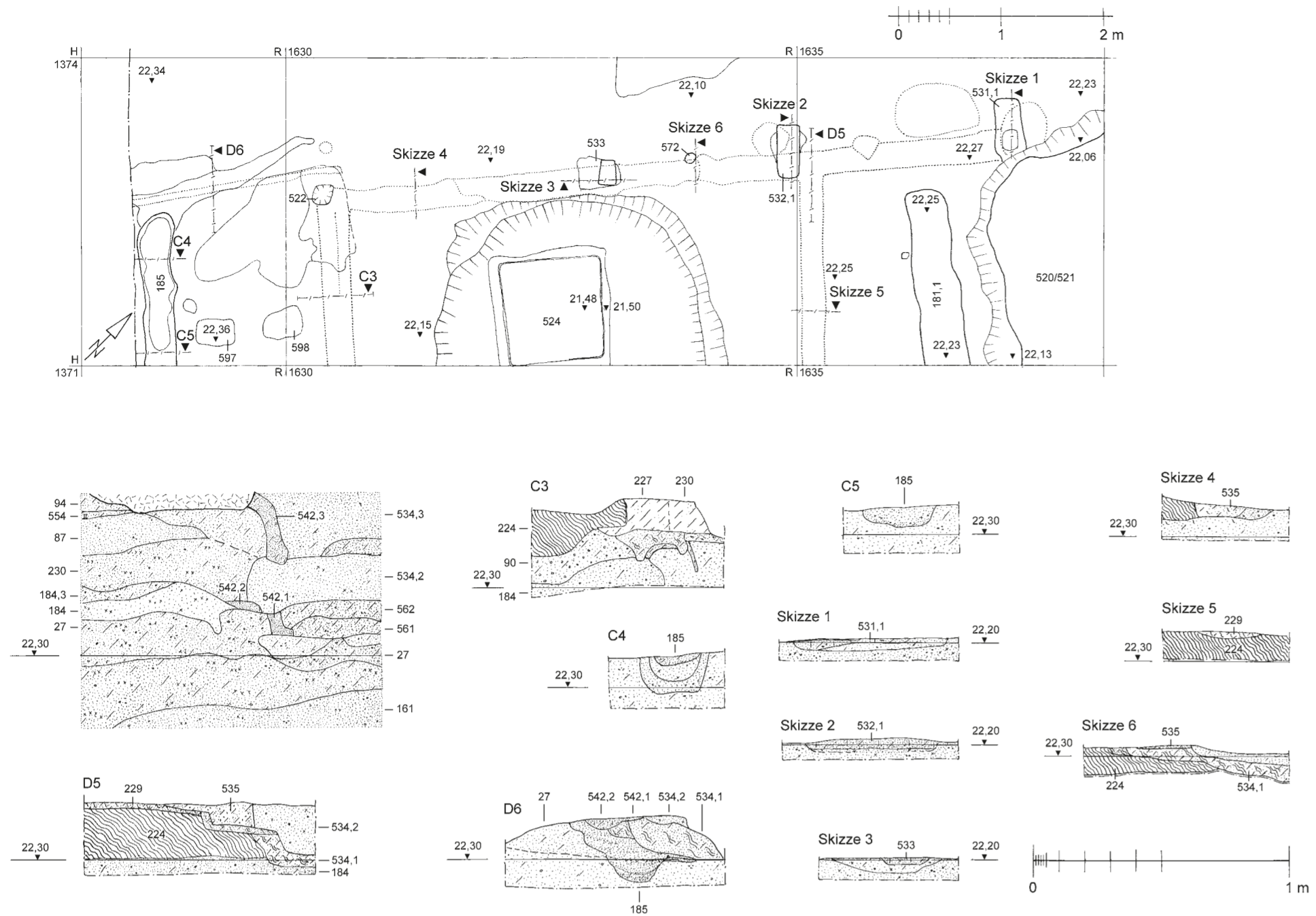

Beilage 11a Oben: Befunde im Schnitt 97/11, 2. Stratum (Ausschnitt); gepunktet = Wandspuren im 1. Stratum. – M. 1:50. – Unten: Schnitt 97/11 Profil D. – M. 1:20.



Beilage 11c Befunde des Ofens 2. – M. 1:20.

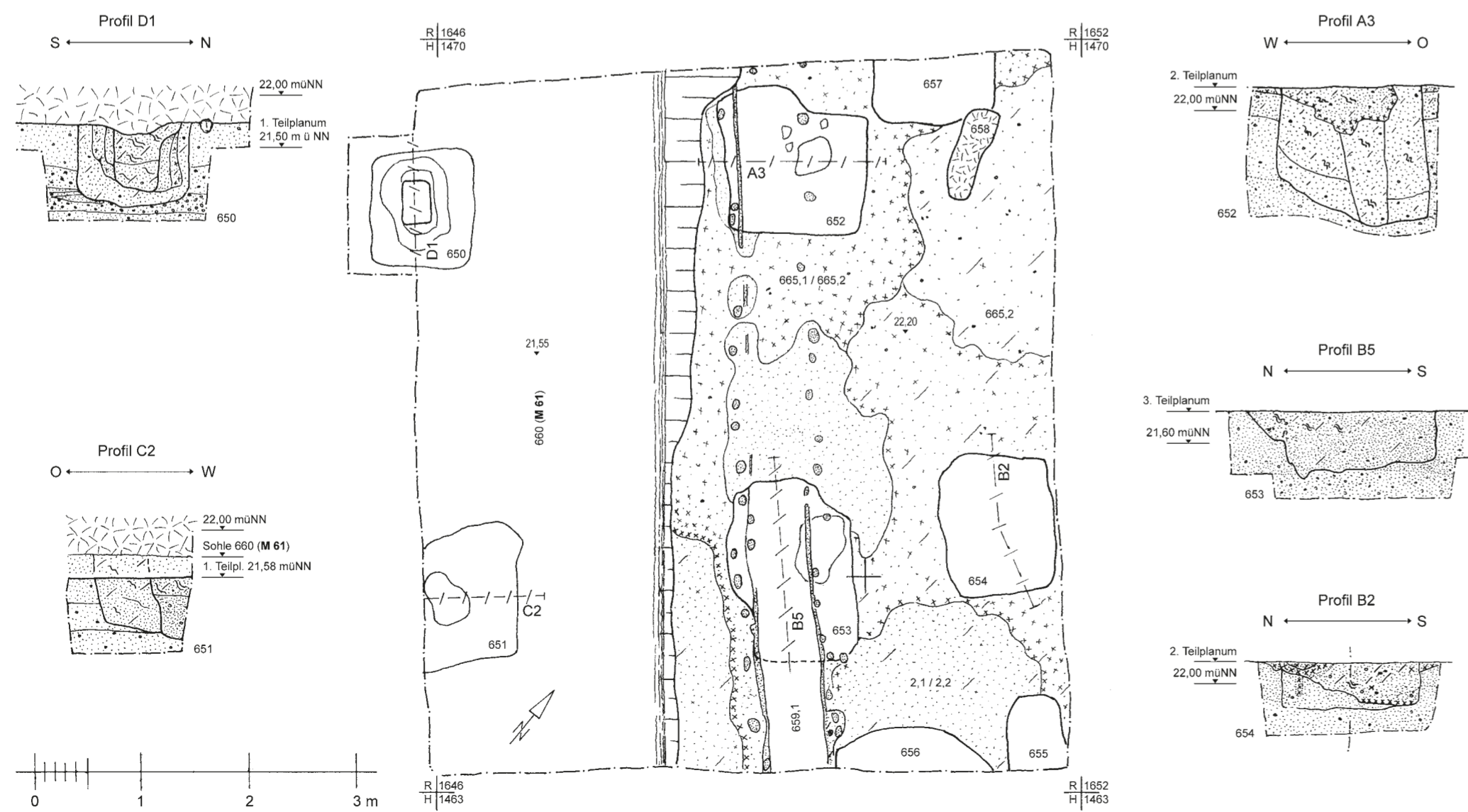

Beilage 11b Befunde im Schnitt 98/3: 1. Teilplanum Sohle 660 (M 61) und 2. Teilplanum (ca. 22,20m ü. NN). – M. 1:50.

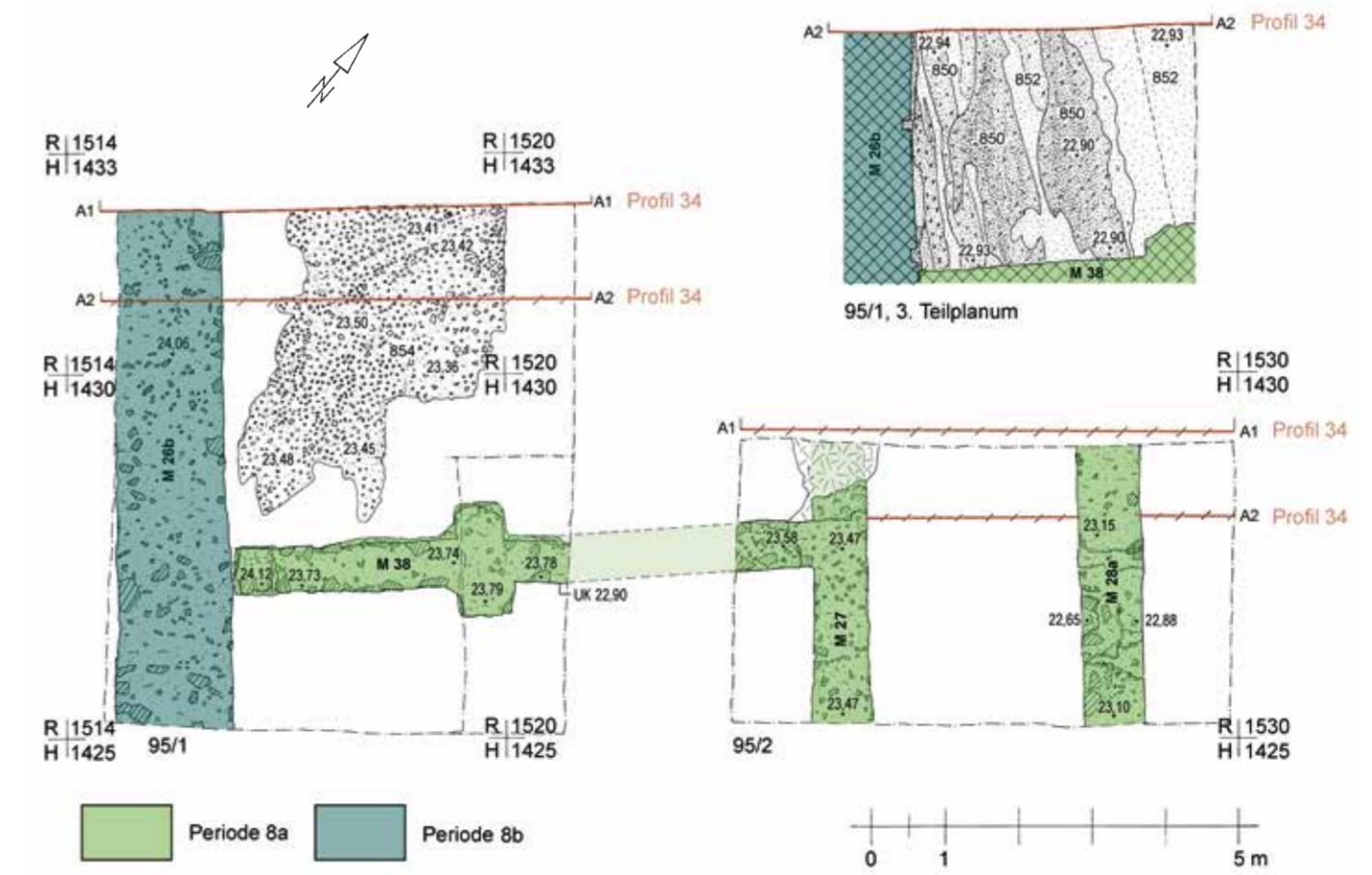

Beilage 11d Befunde im Schnitt 95/1.2. – M. 1:100.

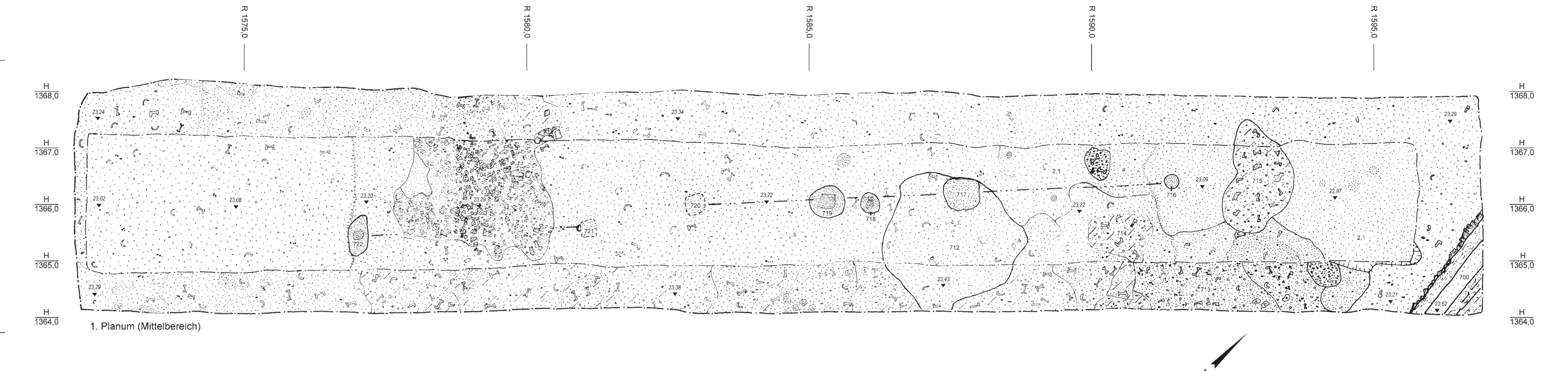
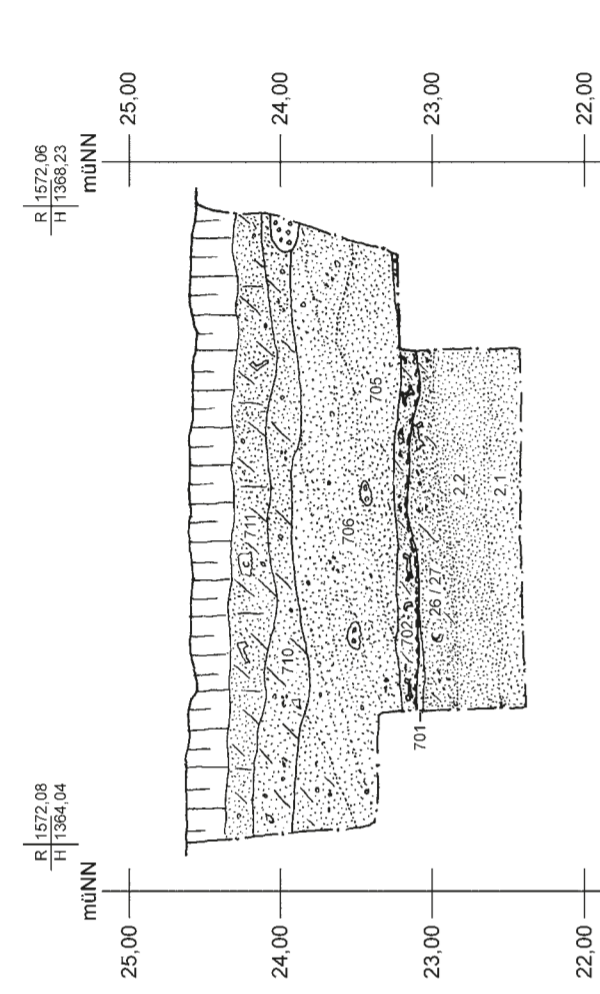
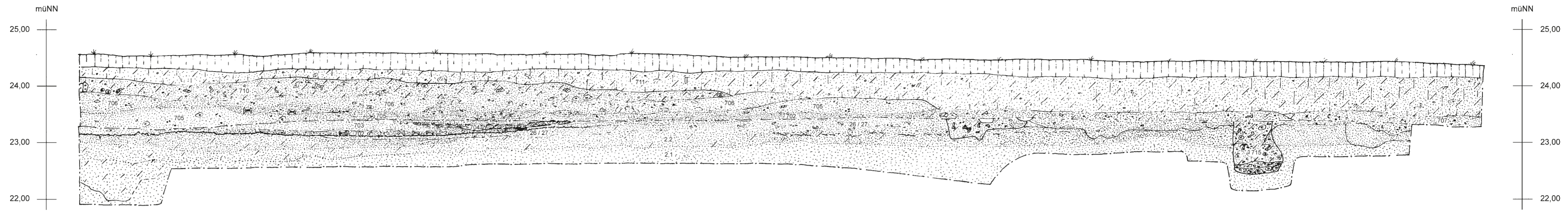

1. Planum (Mittelbereich)

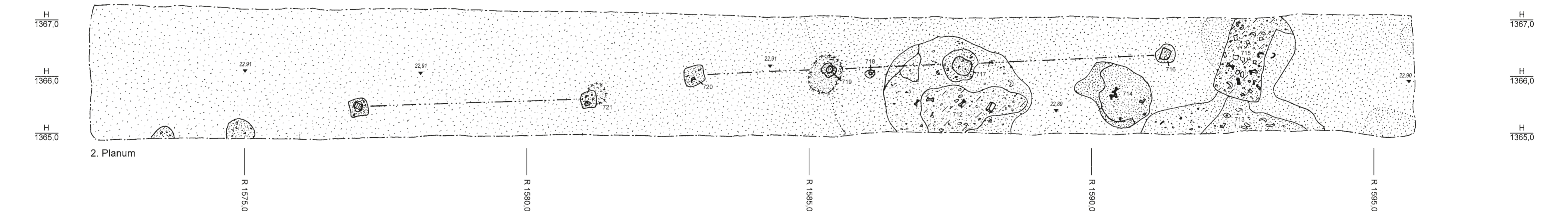

2. Planum

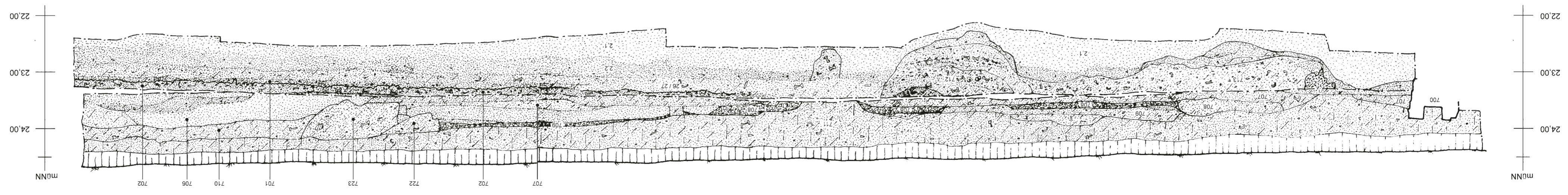

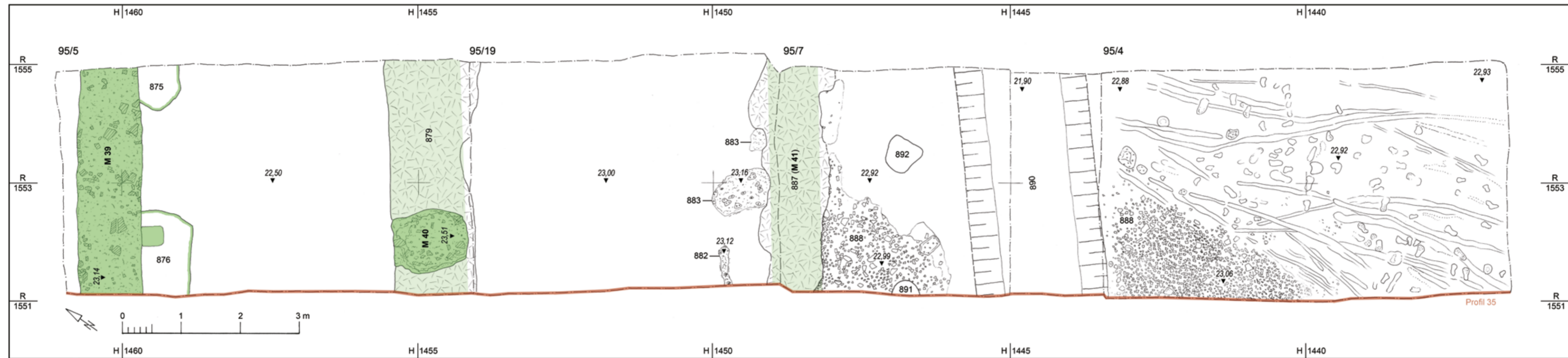

Beilage 13a Befunde in den Schnitten 95/4.5.7.19. – M. 1:50.

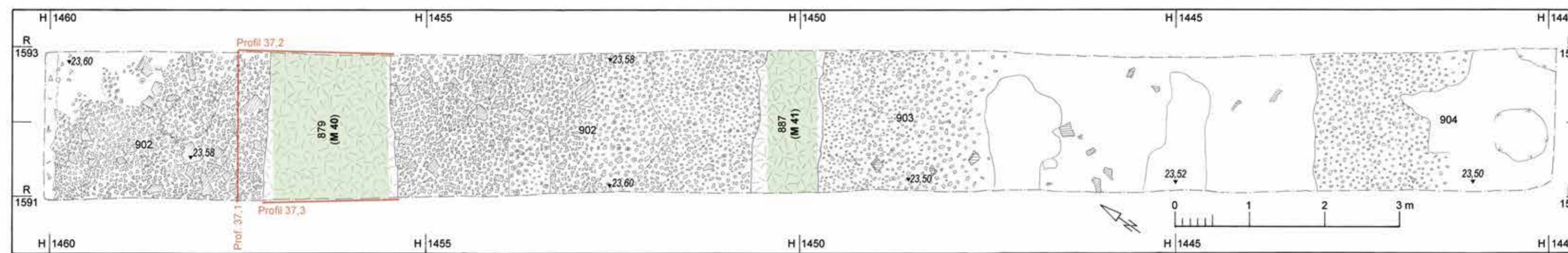

Beilage 13b Befunde im Schnitt 95/20. – M. 1:50.

	Ackerhumus		Ausbruchschutt
	verworfener Humus		Tuffgrus
	dunkler Sand / heller Sand		Knochen
	Lehm		Keramik
	lehmiger Sand		Ziegelbruch
	sandiger Lehm		Grauwacke (-mauerwerk)
	Kiesel		Tuff (-mauerwerk)
	kiesiger Sand		Basalt
	Ton		Trachyt
	Ortstein im Sand		Quarzit
	verziegelter Lehm		Mörtel
	lehmig / verziegelter Lehm		Grauwackemauerwerk, geschnitten
	Holzkohle		Mauerwerk: steingerecht / linear dokumentiert
	Laufhorizont		23.51 Niveau der erhaltenen Oberkante in m ü. NN
	Opus signinum Estrich		22.90 Niveau der Befundsohle in m ü. NN
	Graben		Grabungsgrenze
	Grubenrand		Befund vorhanden, aber verdeckt (oberhalb / unterhalb)
	Grenze eines Störungsbereichs		Befund rekonstruiert
	Rinnen- / Mauerkontur oberhalb des Planums		Befund gesichert, aber ergänzt
	Befund / -Ergänzung		Lage eines Profils

Legende zu den Grundrissen und Profilen.

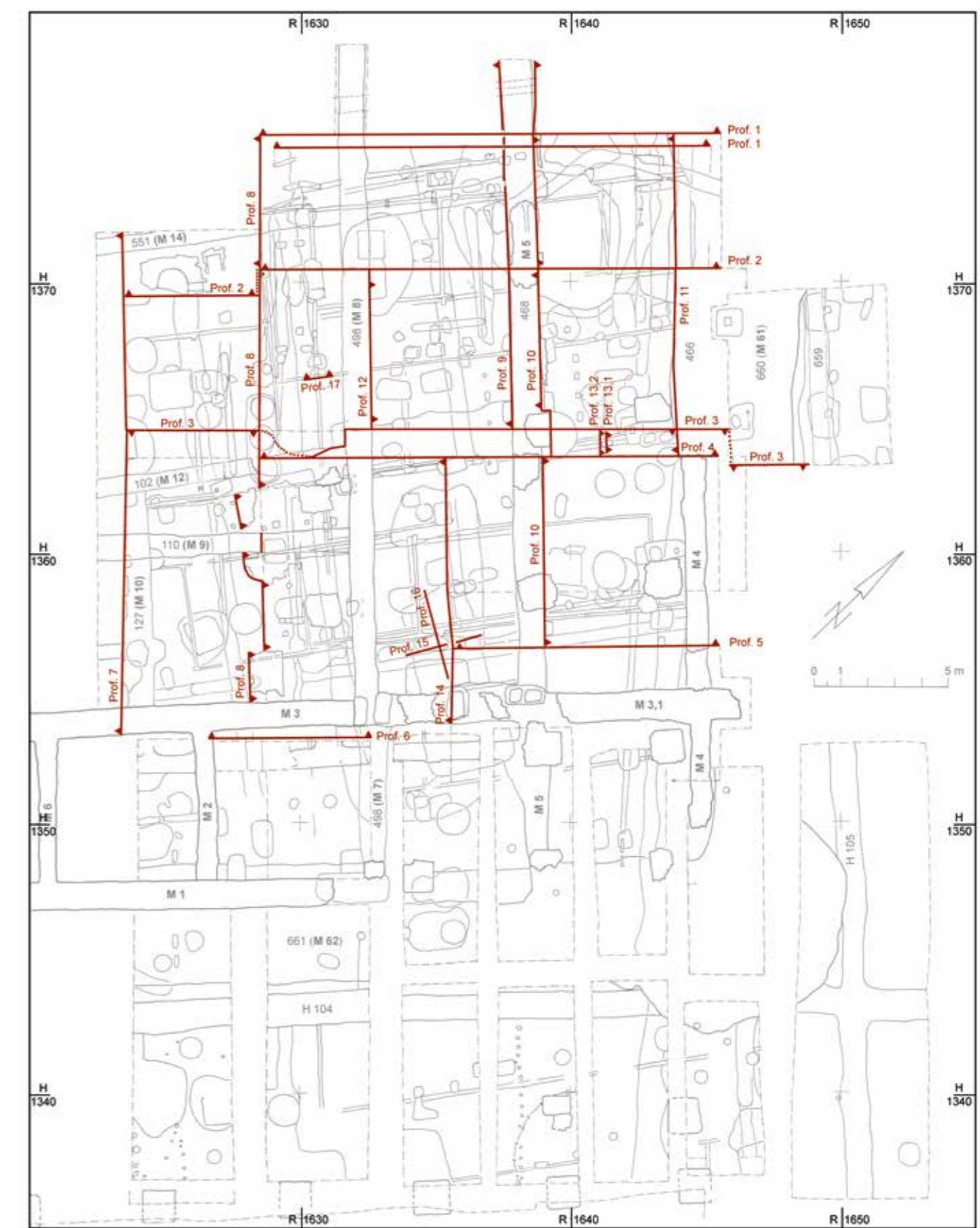

Beilage 14a Lage der Hauptprofile. – M. 1:200.



Beilage 14b Lage der Profile im Apsidenbau. – M. 1:200.

Profil 3

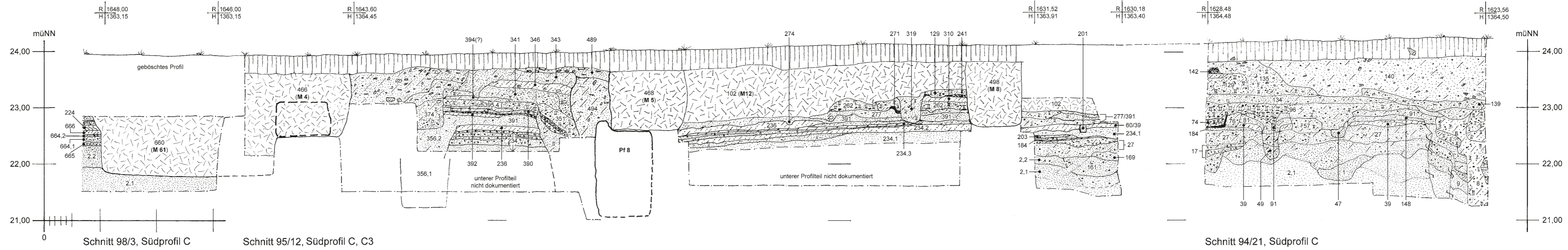

Profil 4

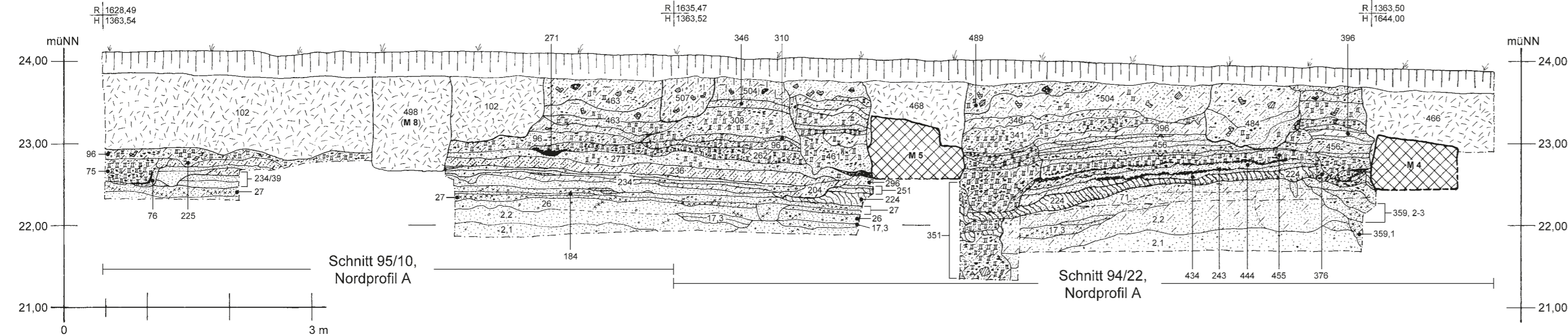

Profil 5

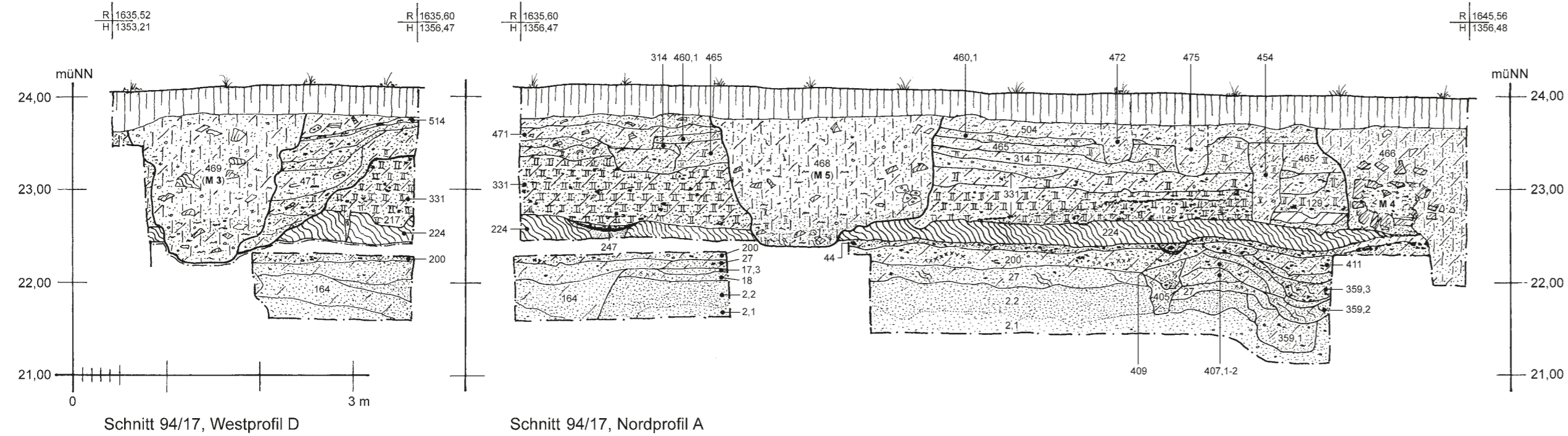

Profil 6

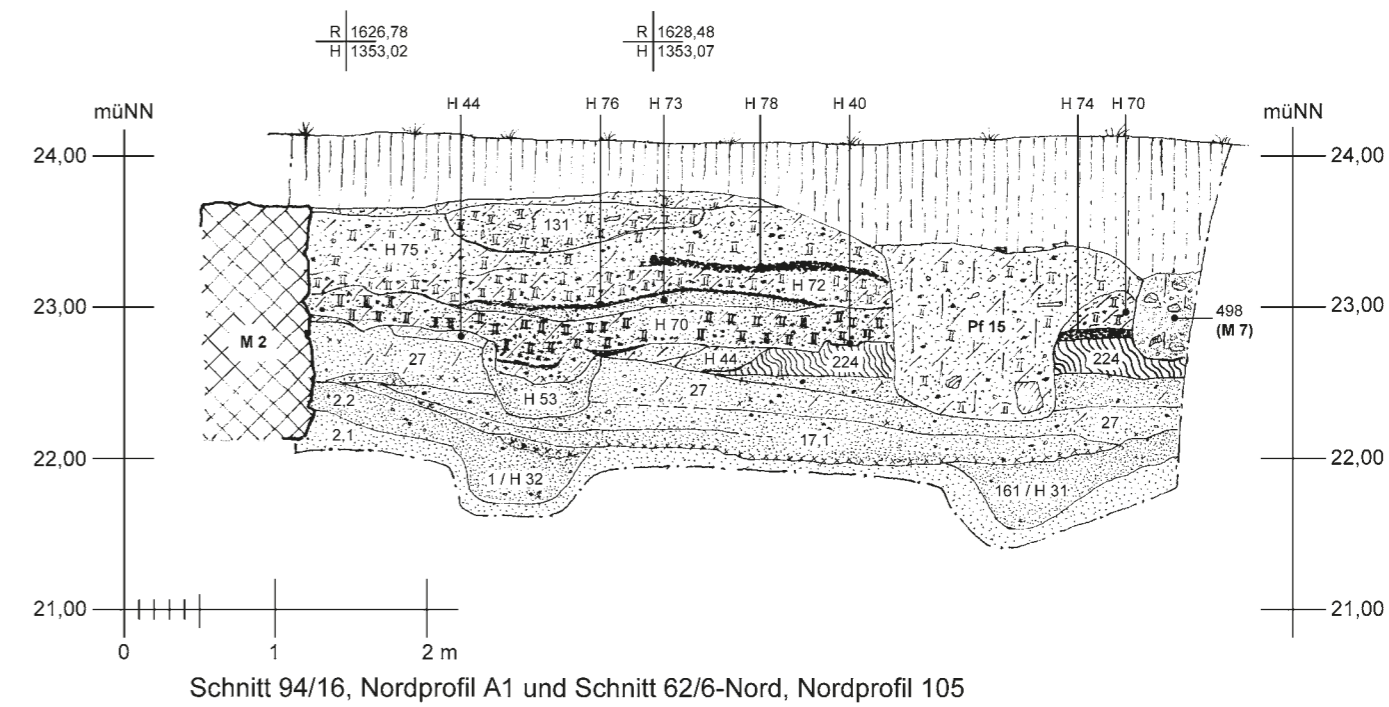

Profil 7

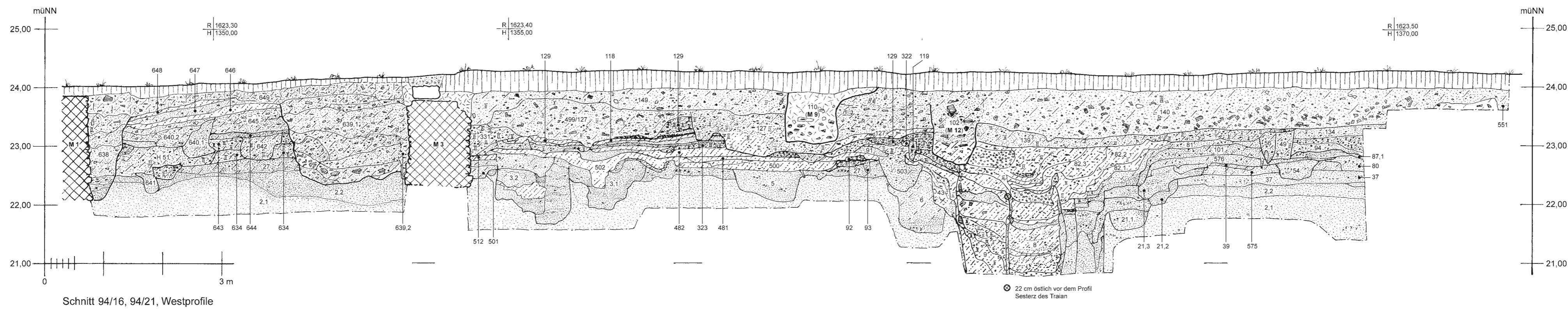

Profil 8

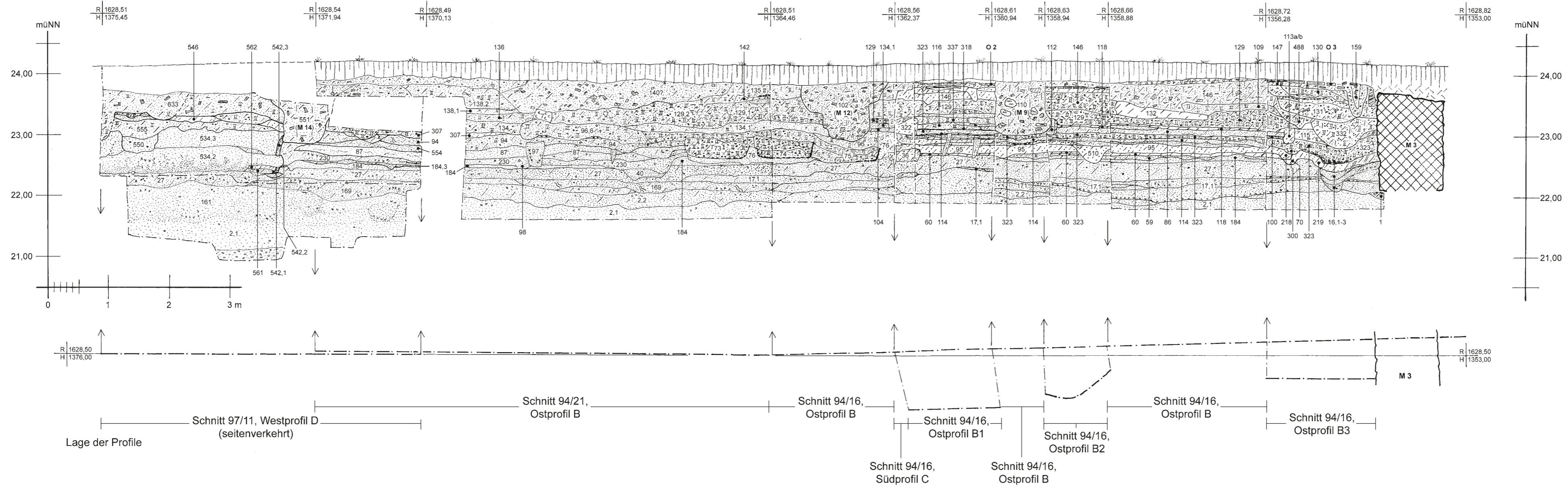

Profil 9

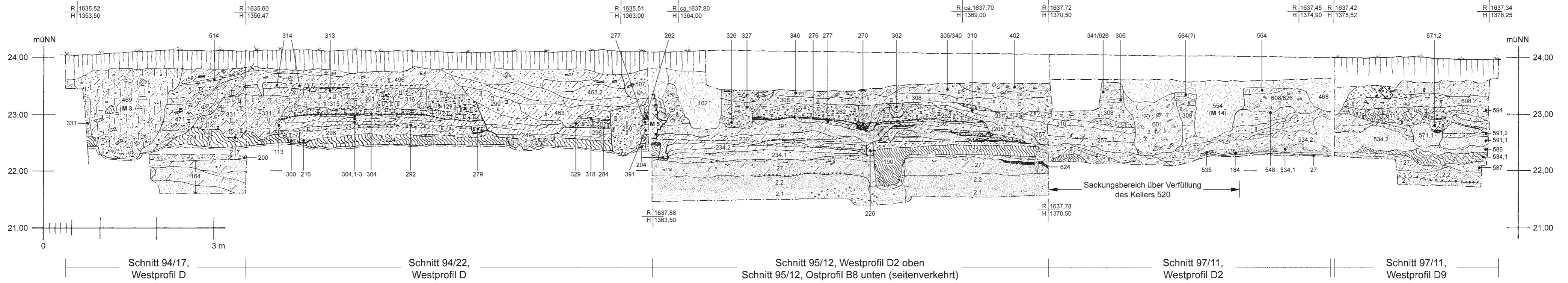

Profil 10

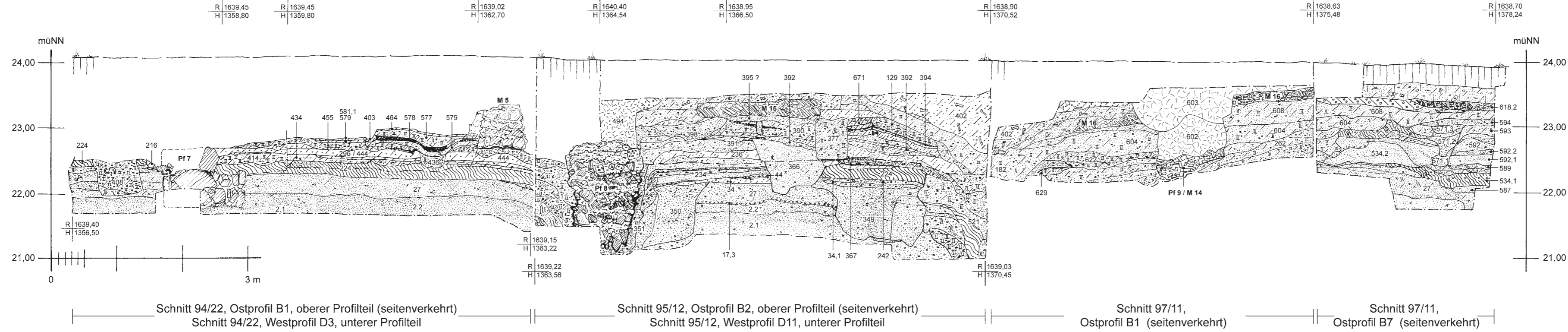

Profil 11

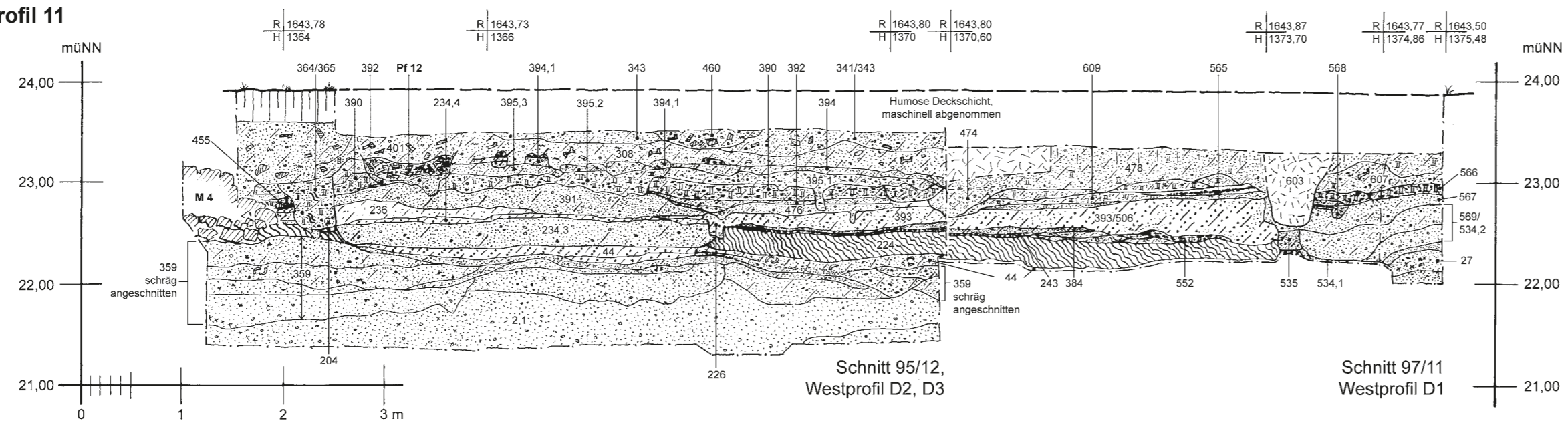

Profil 13,1

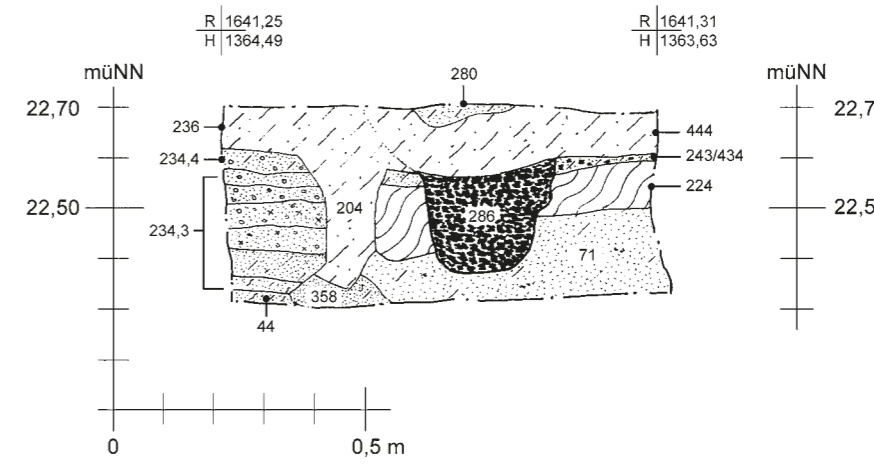

Profil 12

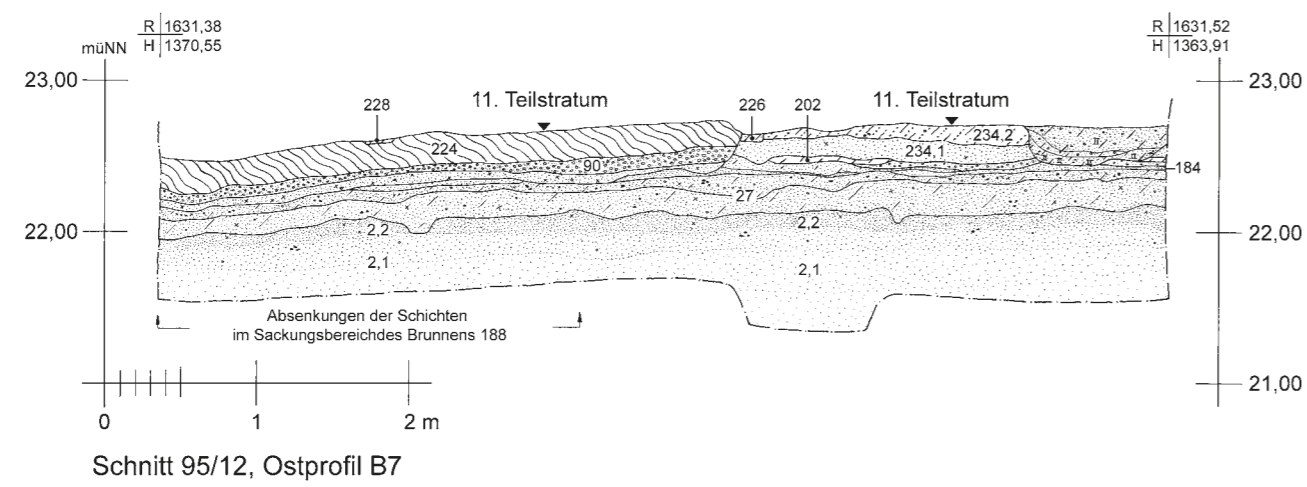

Profil 13,2

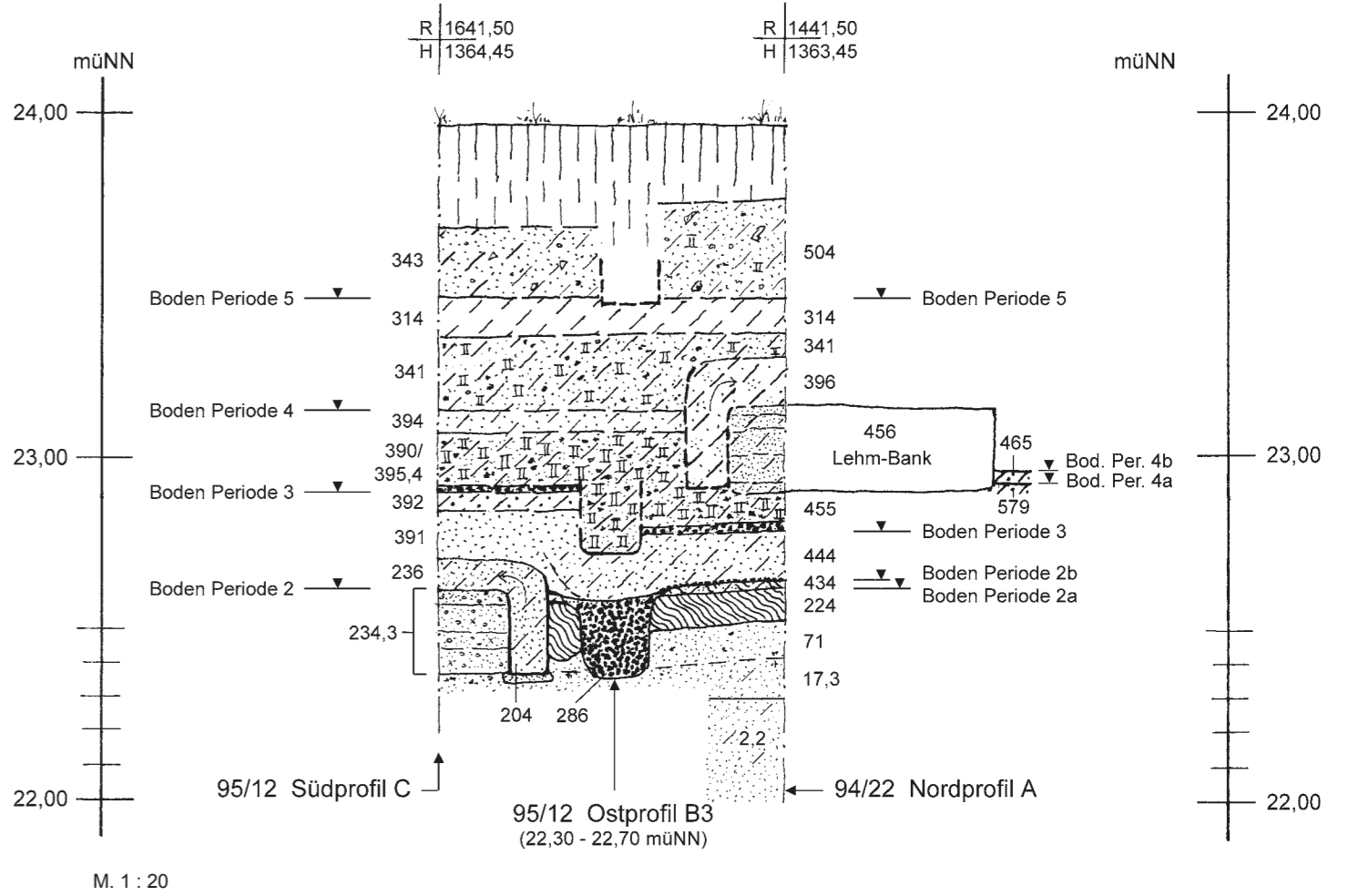

Profil 14

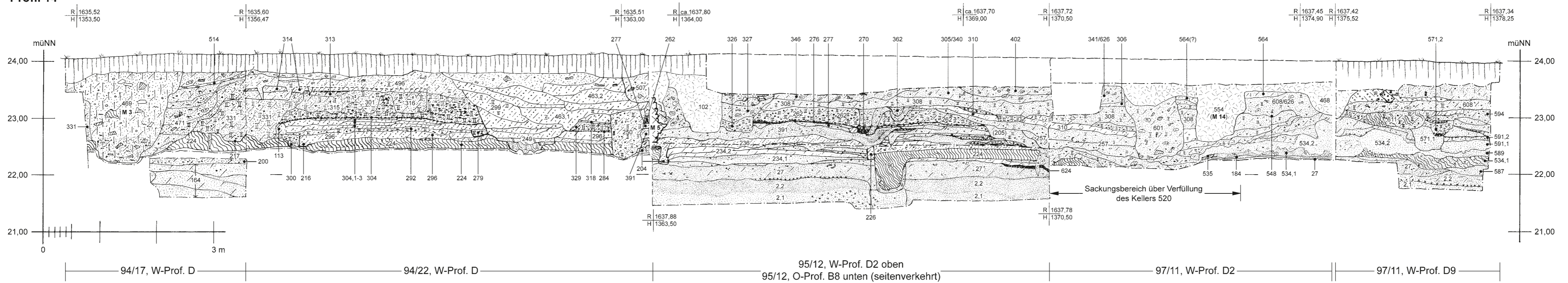

Profil 15

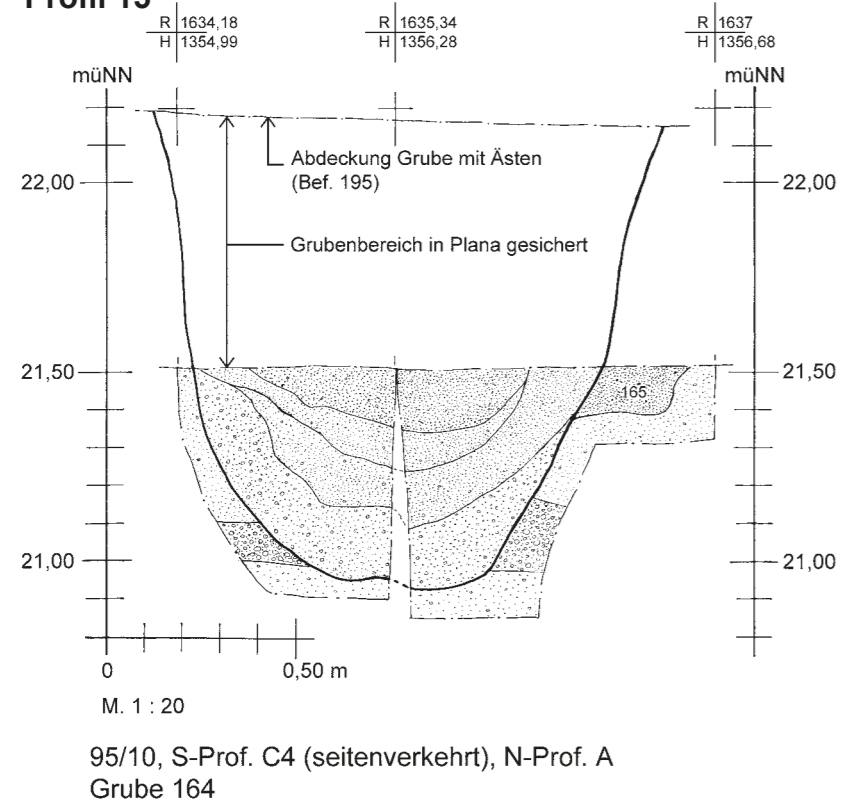

Profil 16

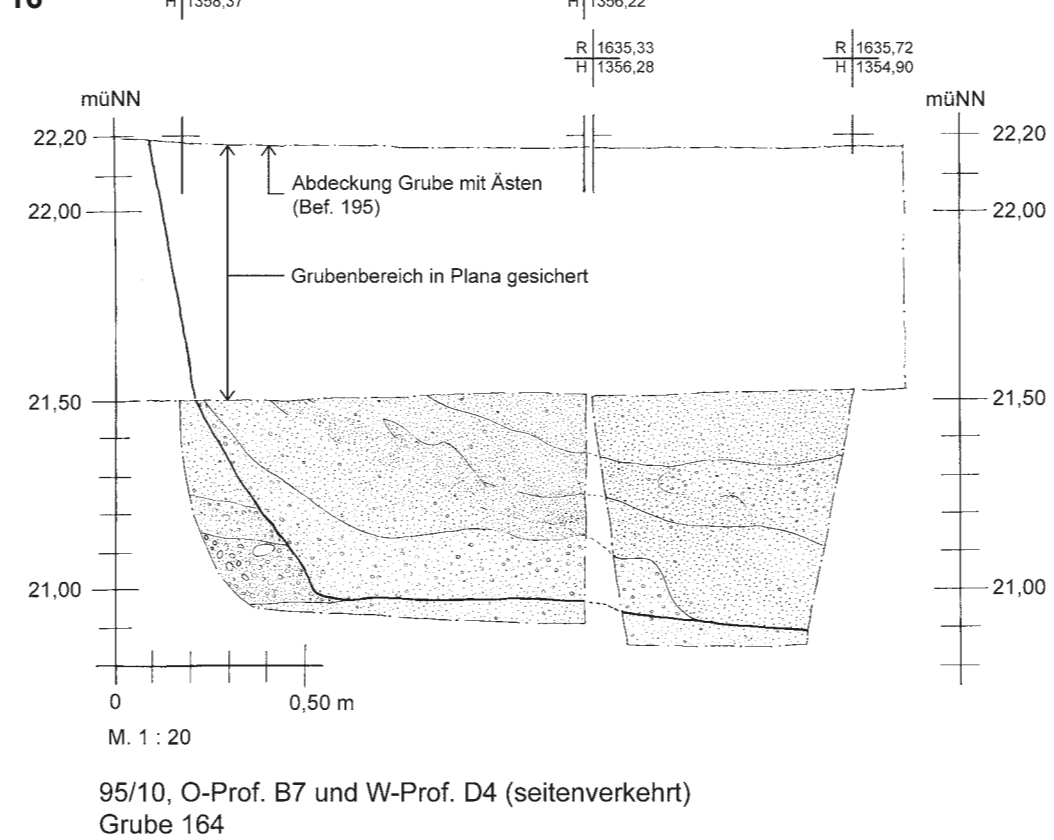

Profil 17

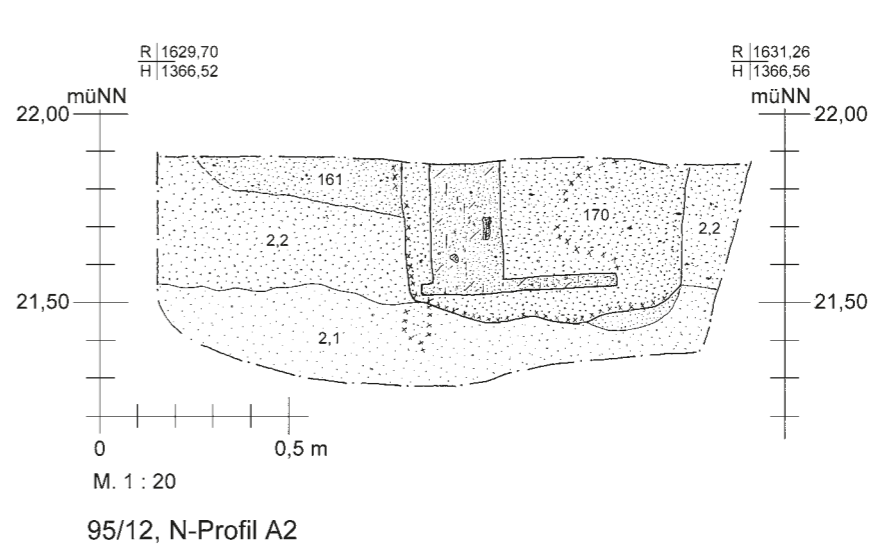

Profil 23

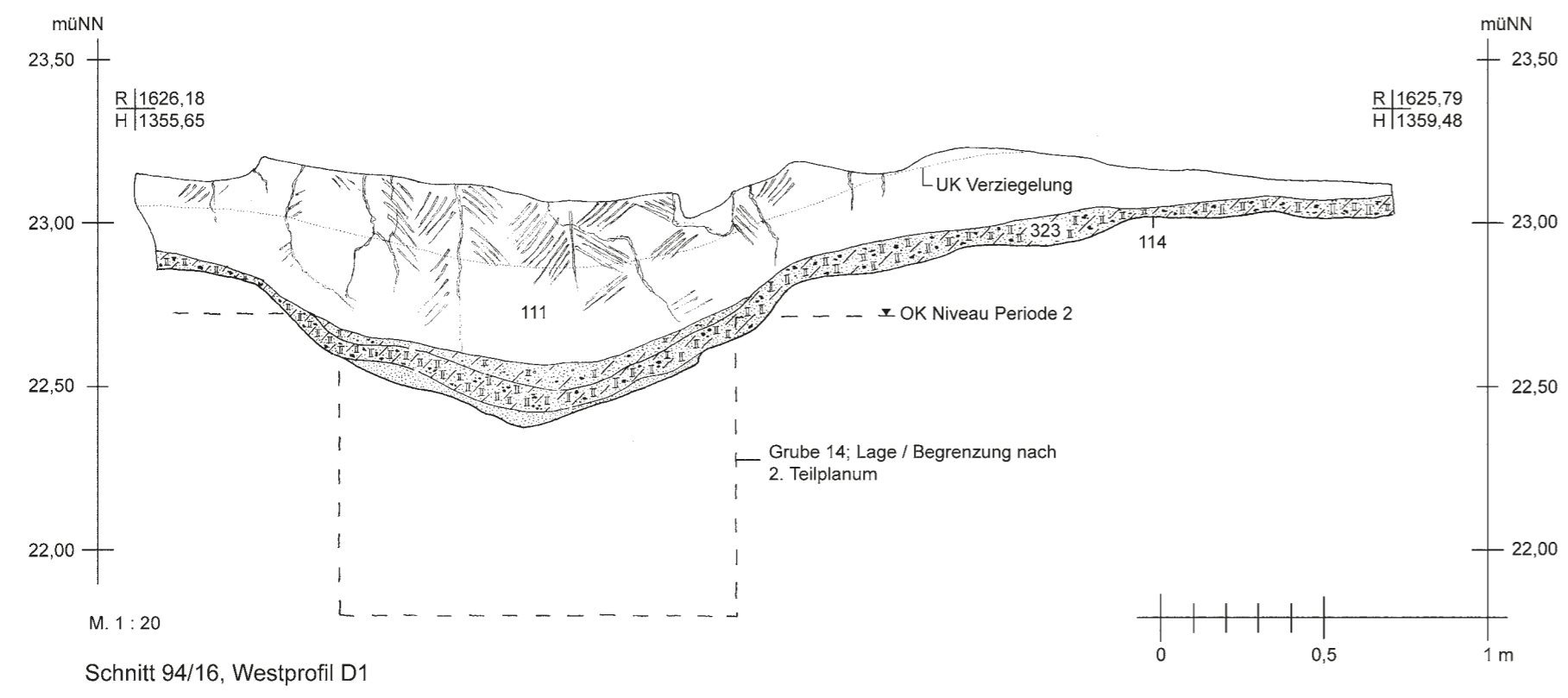

Profil 24

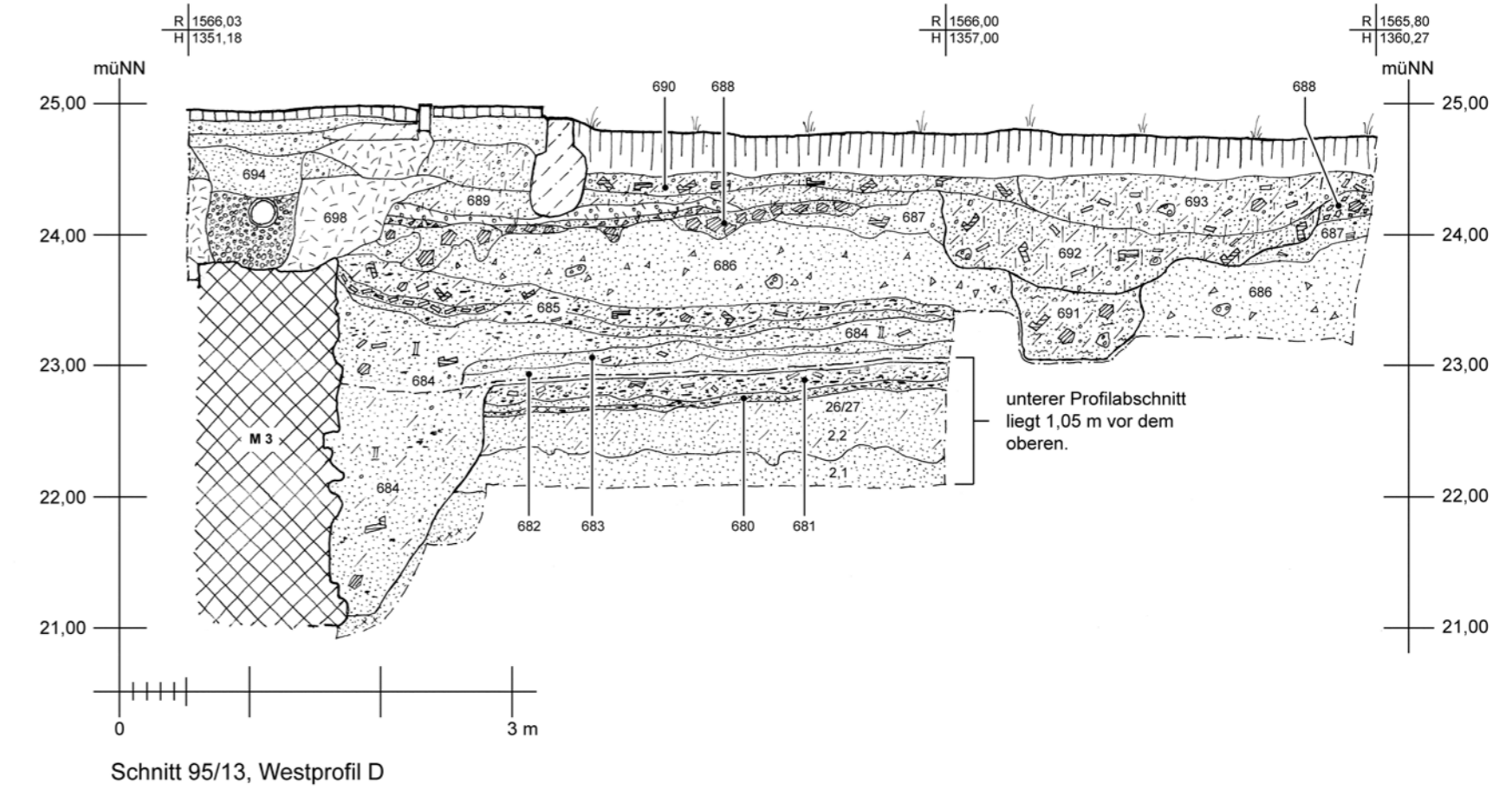

Profil 25,1

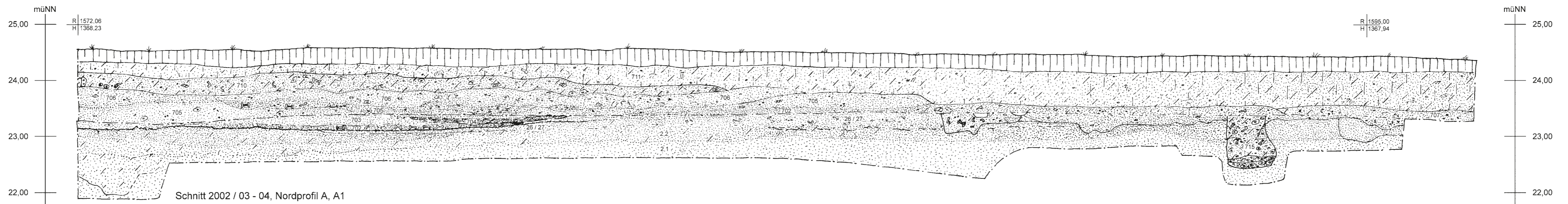

Profil 25,2

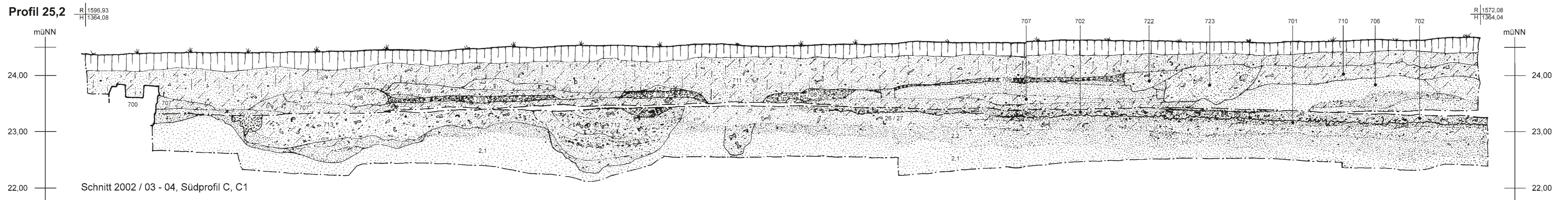

Profil 25,3

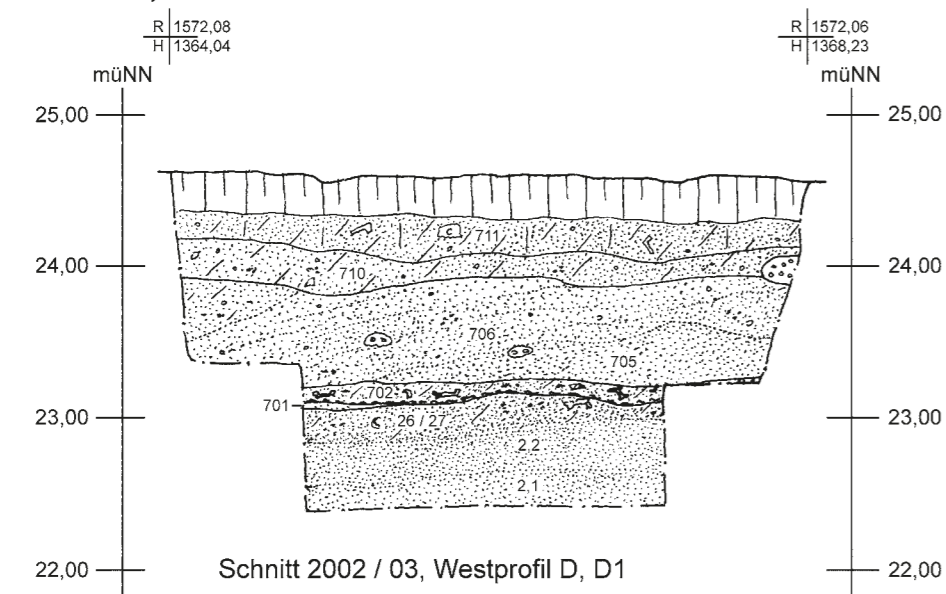

Profil 26

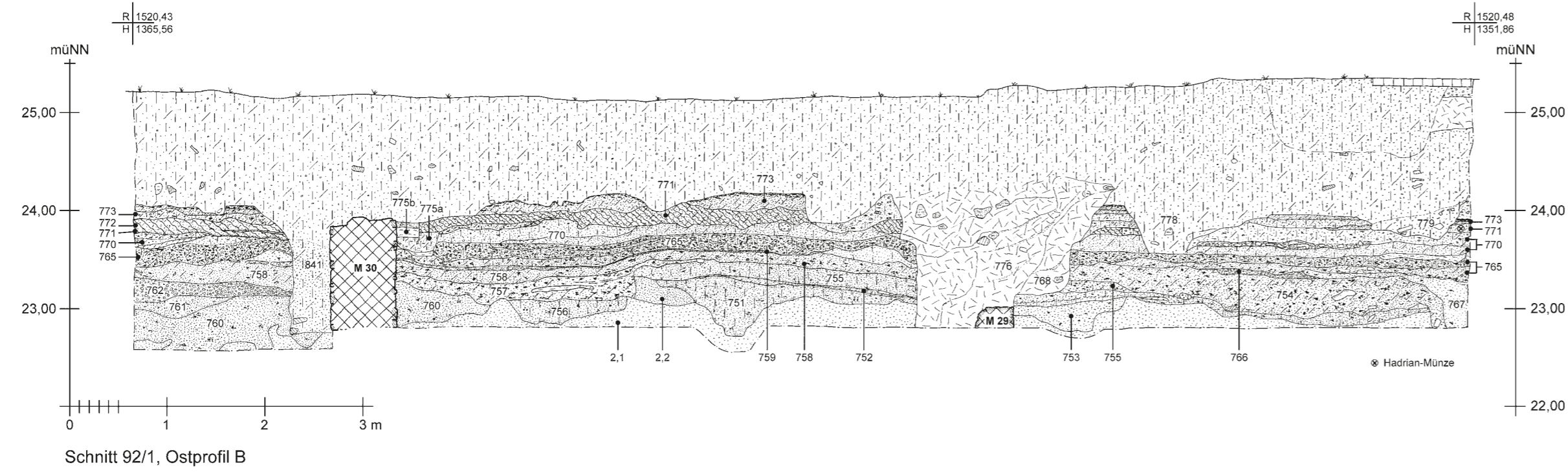

Schnitt 92/1, Ostprofil B

Profil 27

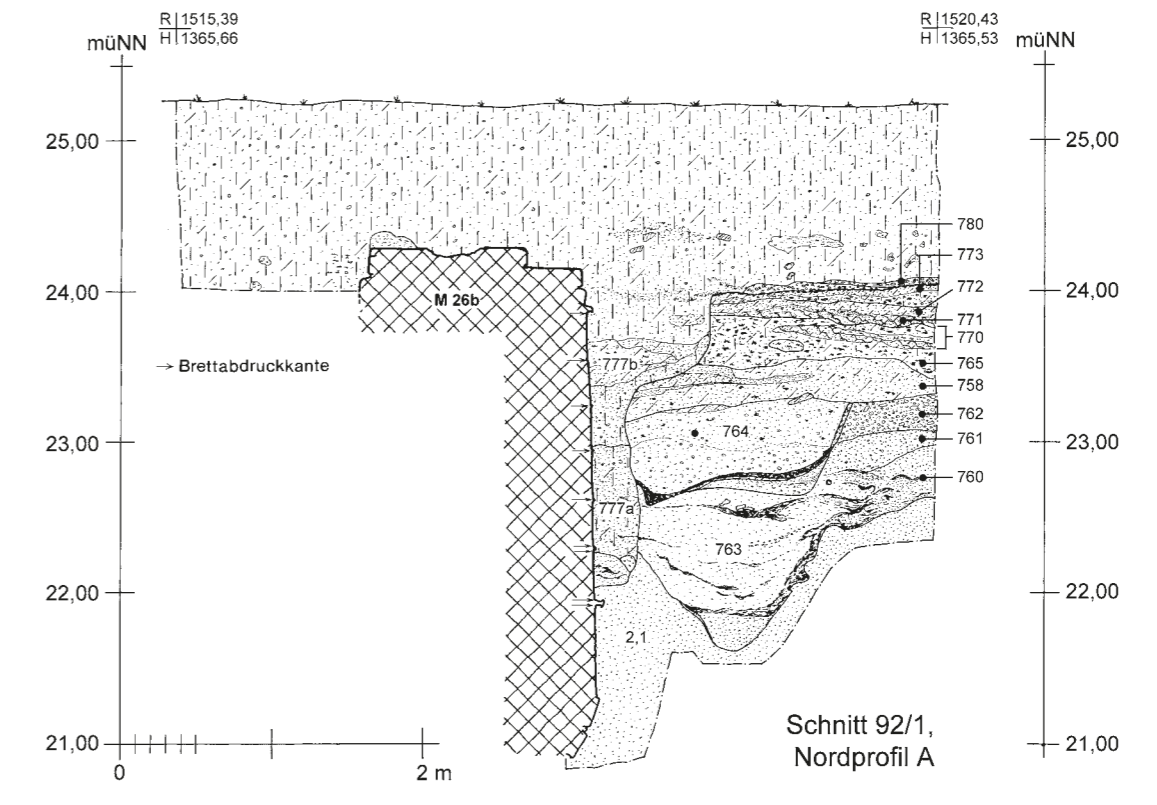

Schnitt 92/1, Nordprofil A

Profil 28

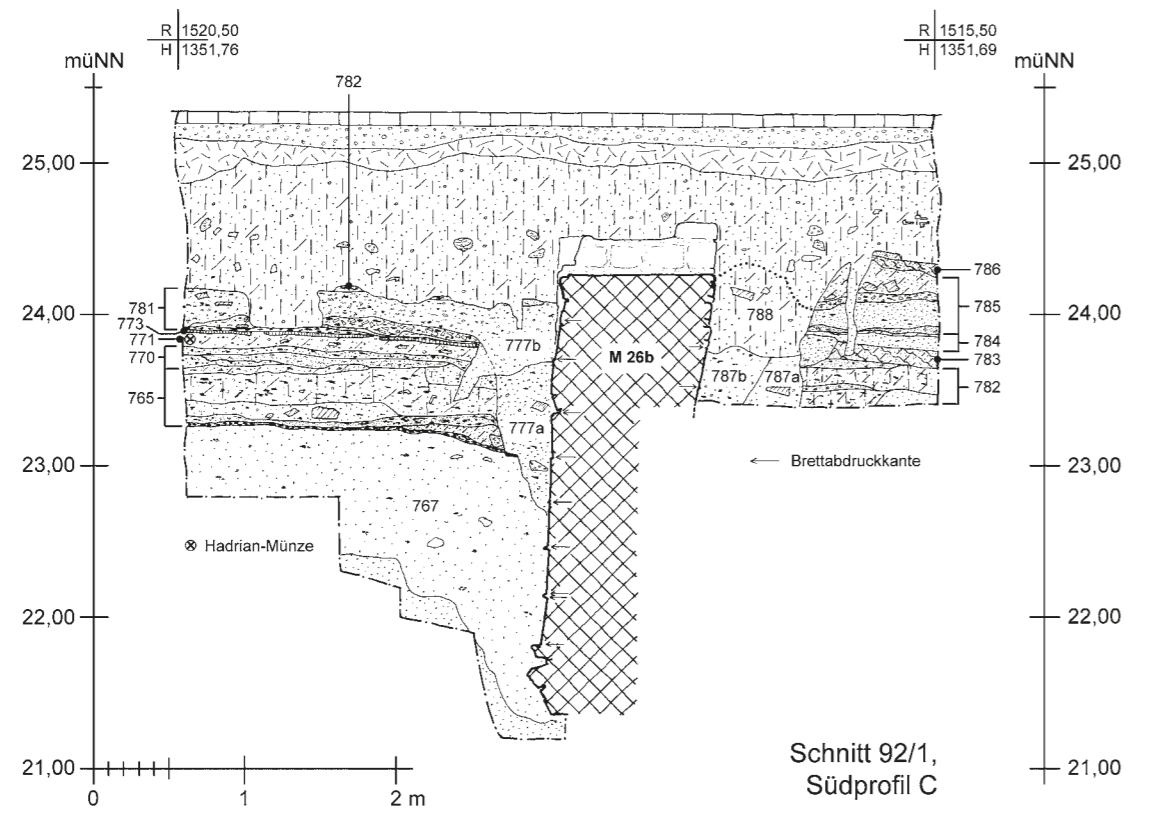

Schnitt 92/1, Südprofil C

Profil 29

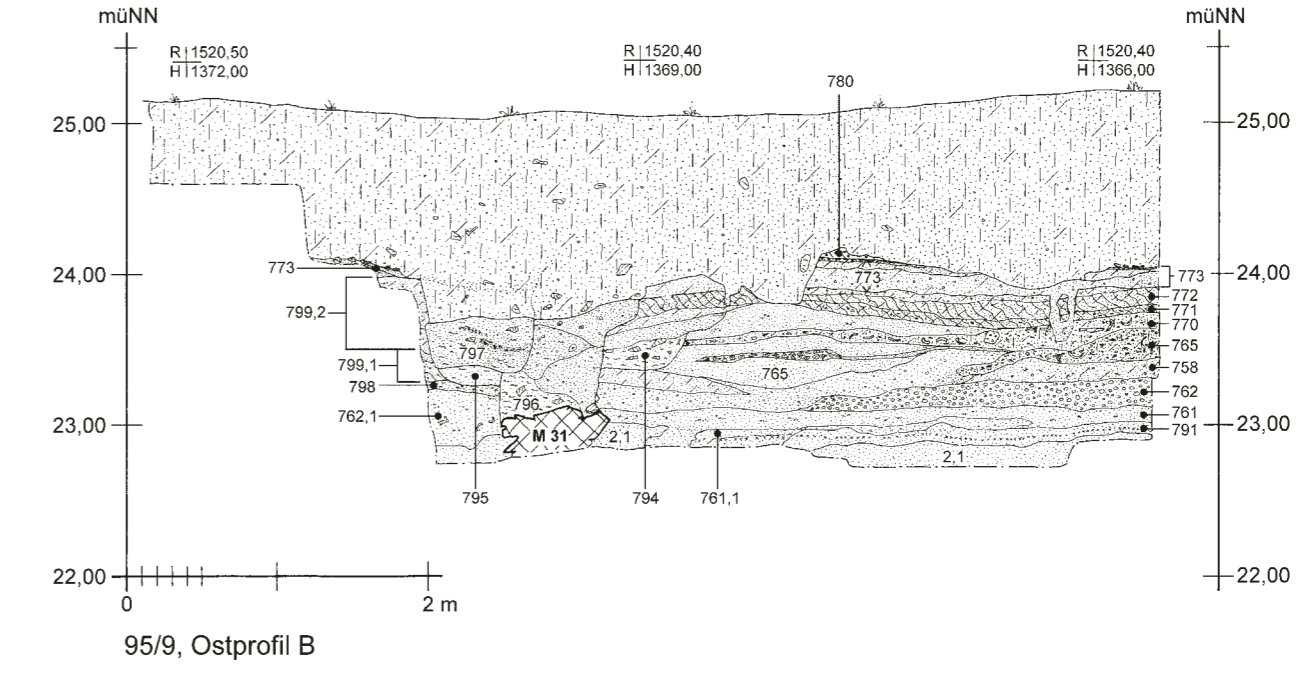

Profil 30

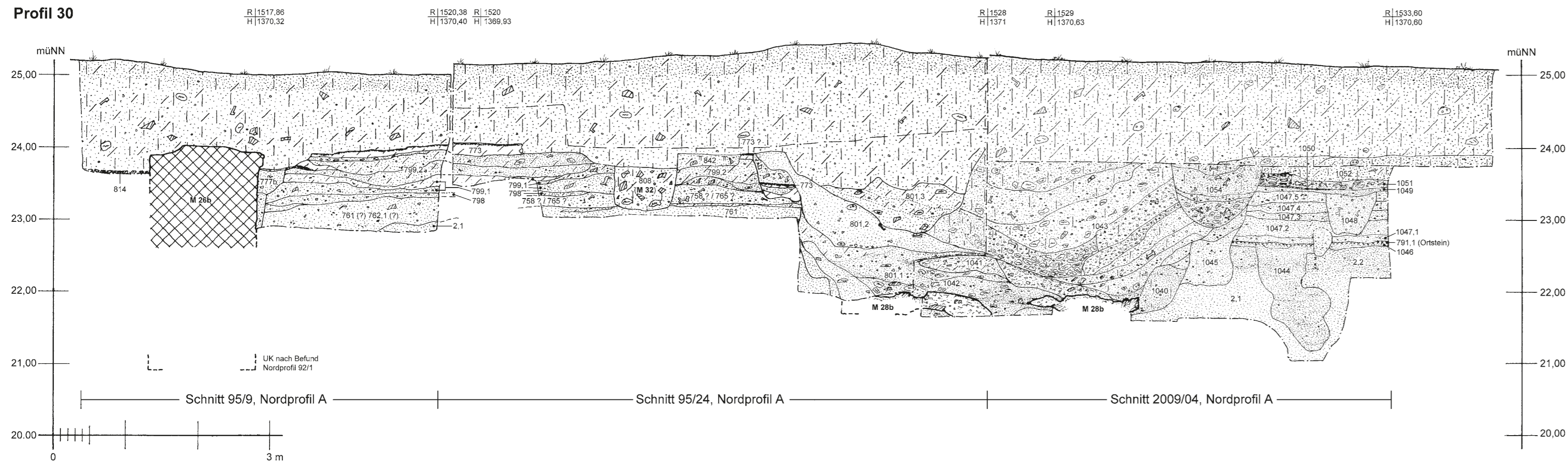

Profil 31

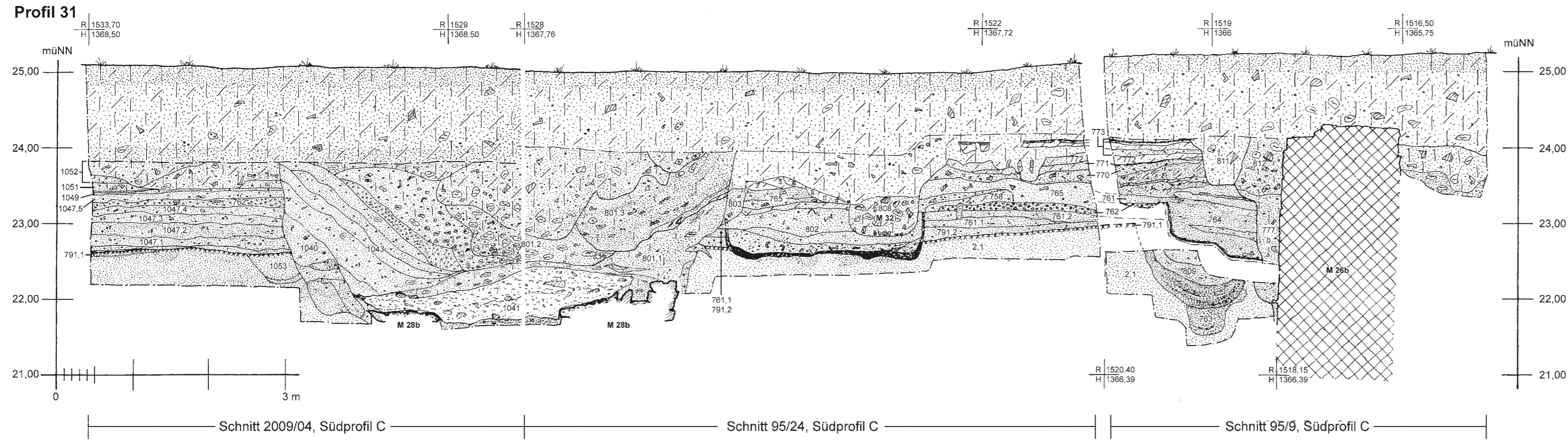

Profil 32

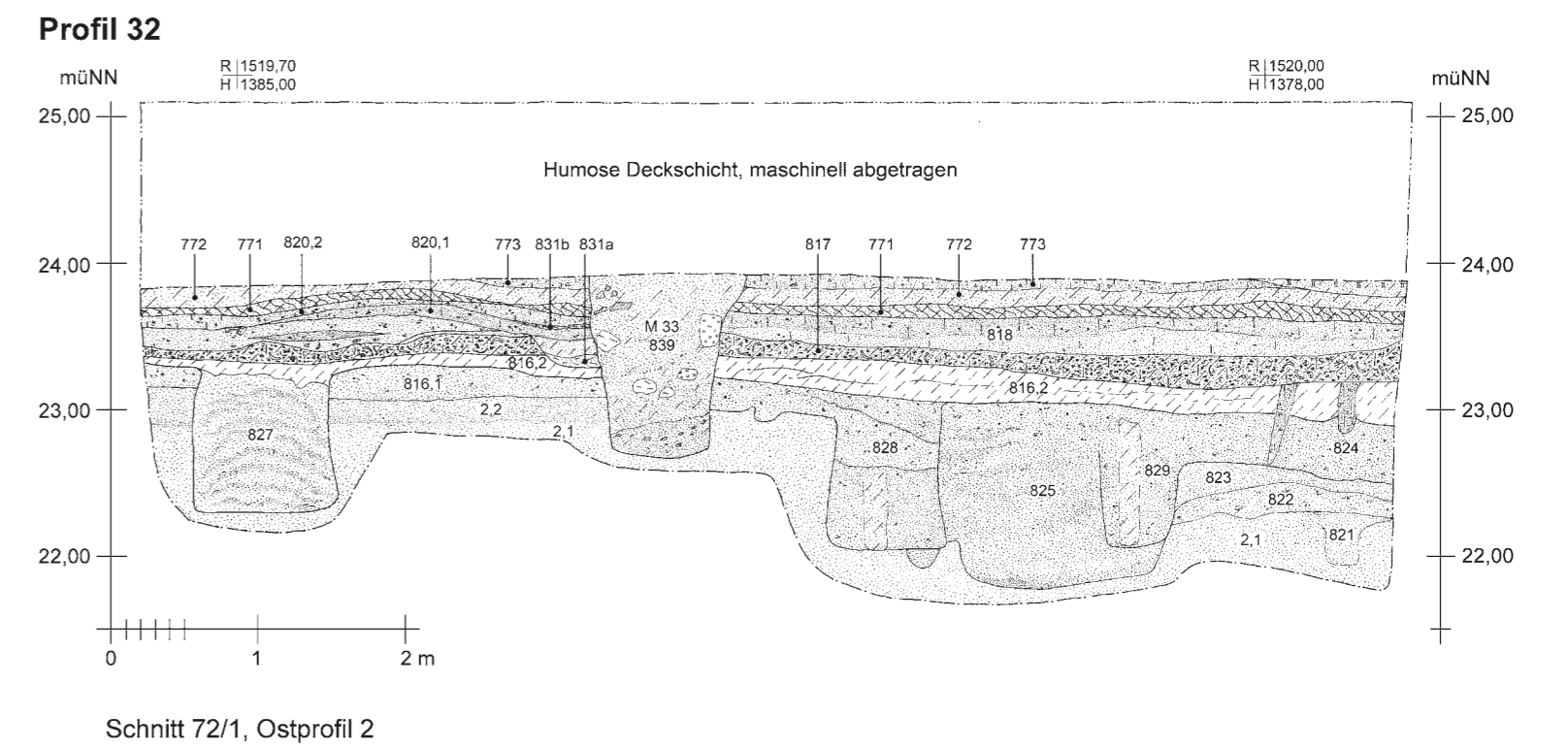

Profil 33

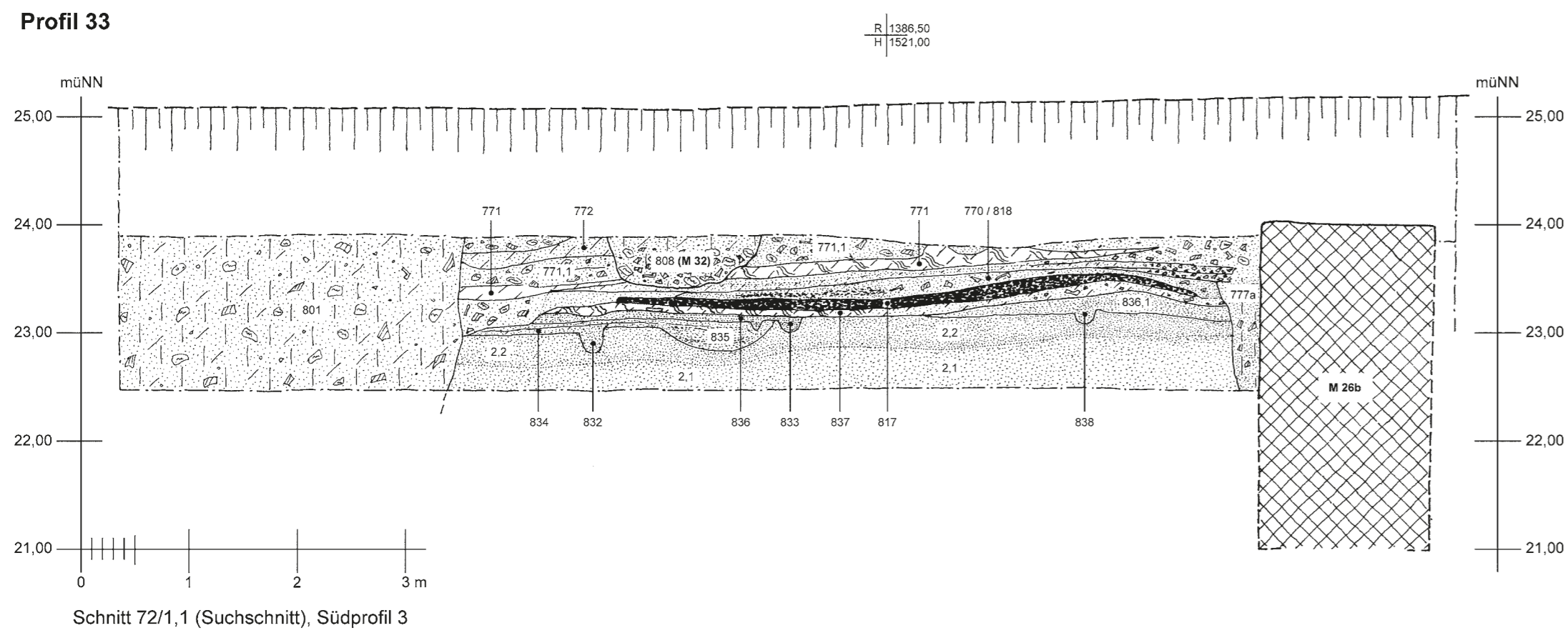

Profil 34

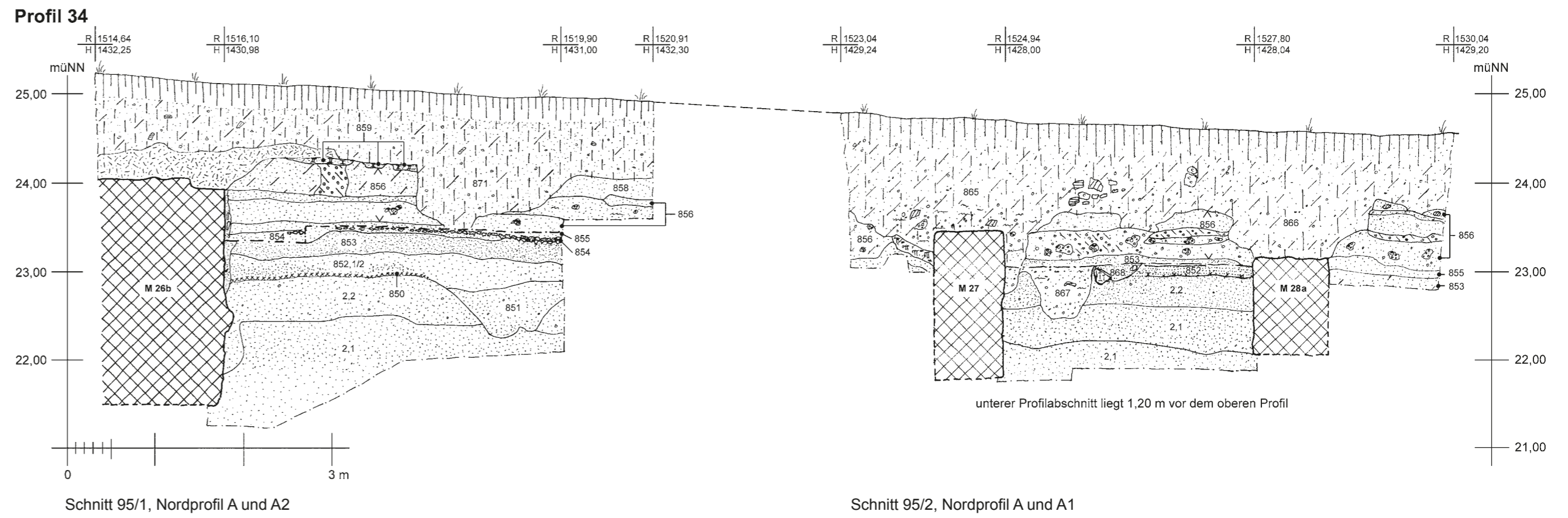

Profil 35

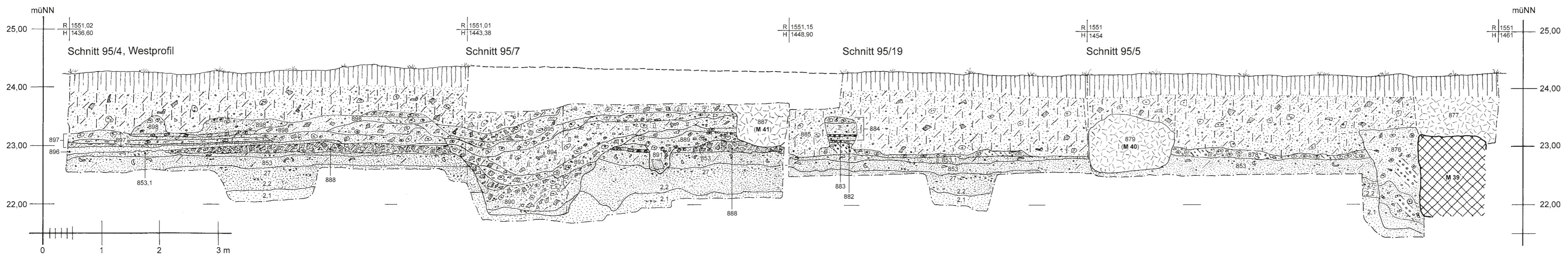

Profil 36

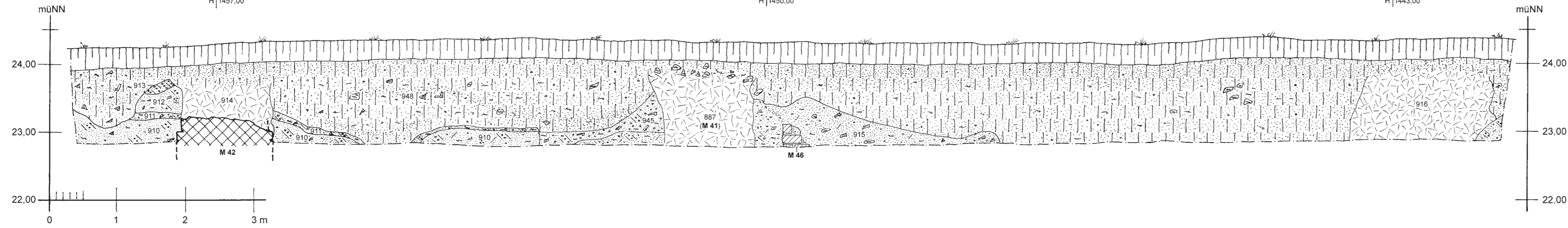

Schnitt 95/26, Ostprofil B

Profil 37,2

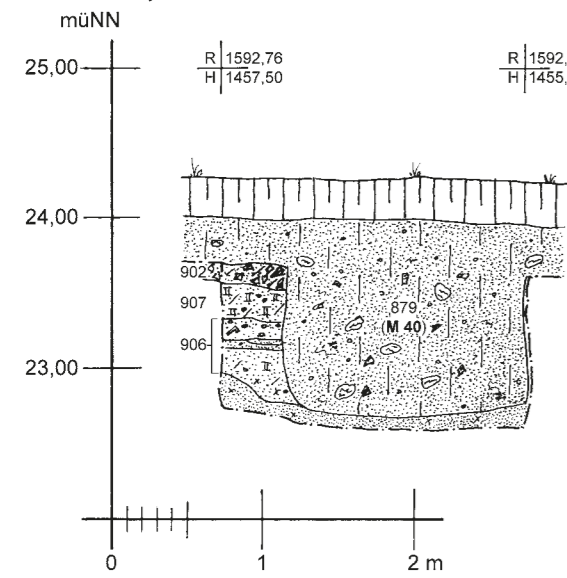

Schnitt 95/20 Ostprofil B1

Profil 37,1

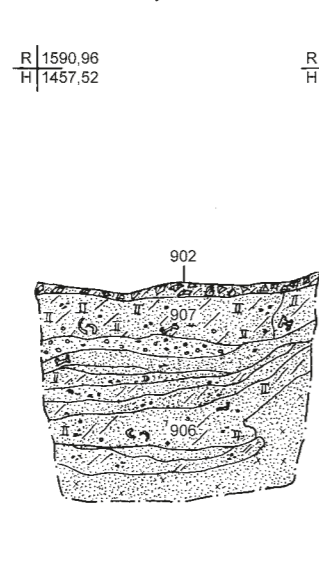

Nordprofil A3

Profil 37,3

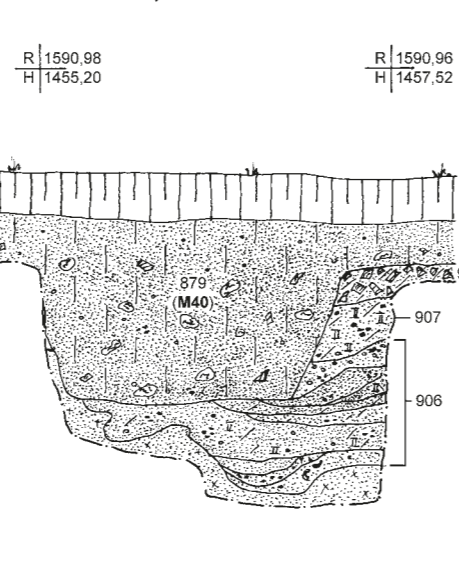

Westprofil D1

Profil 38,1

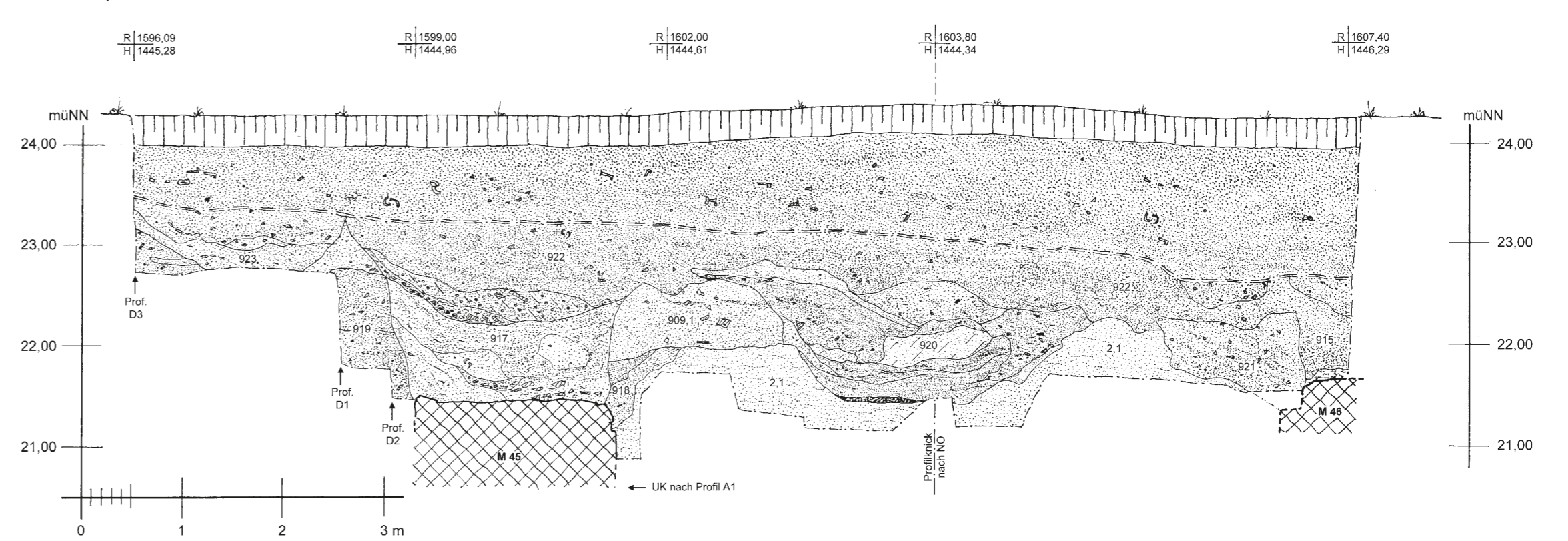

Schnitt 96/1, Nordprofil A, A2 (oben). Koordinaten für unteren Profileteil A, oberer Profileteil A2 ca. 1,20 m zurückspringend

Profil 38,2

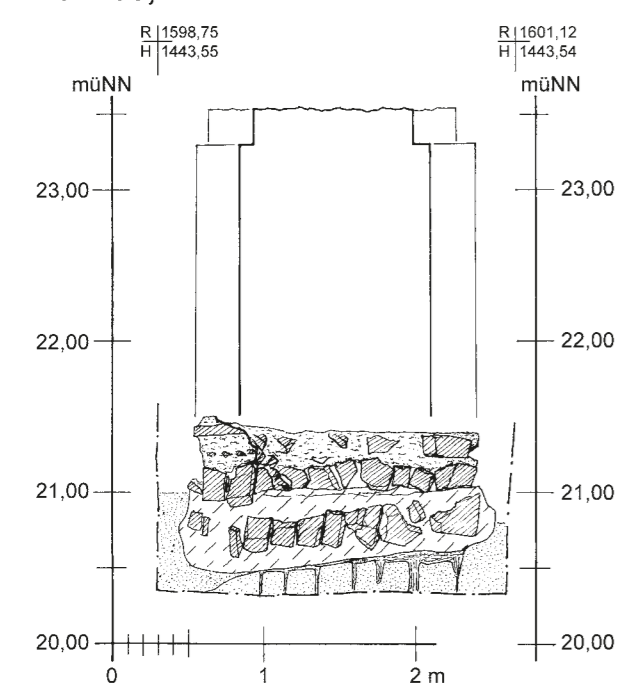

Fundamentfuß Mauer M 45 in Höhe der Koordinaten H 1458,37 / R 1627,0; Aufgehendes Mauerwerk nach Mauer M 42.

Profil 39

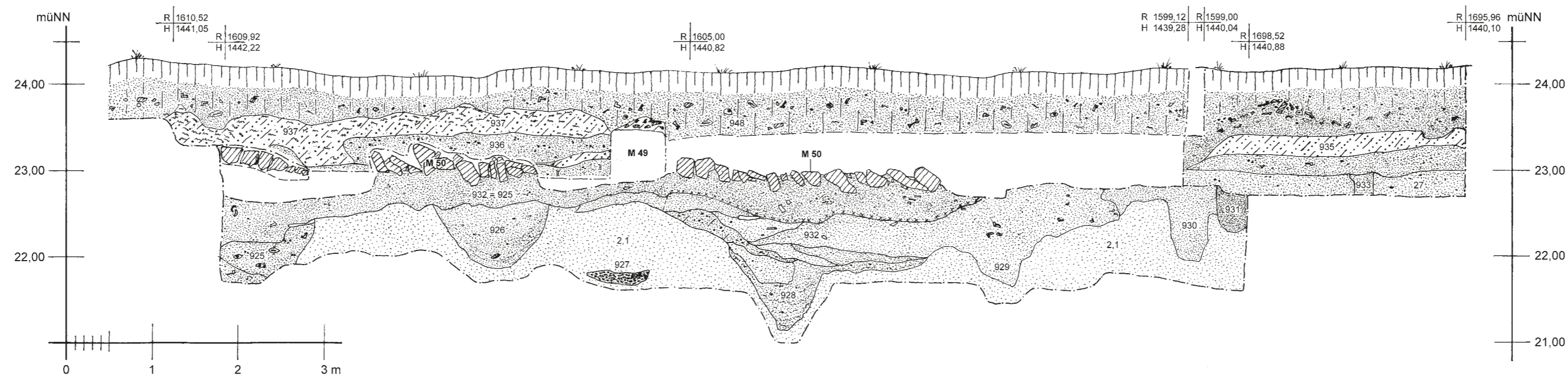

Schnitt 96/1, Südprofil C (unten), C1 (rechts oben), C2 (oben)

Profil 40

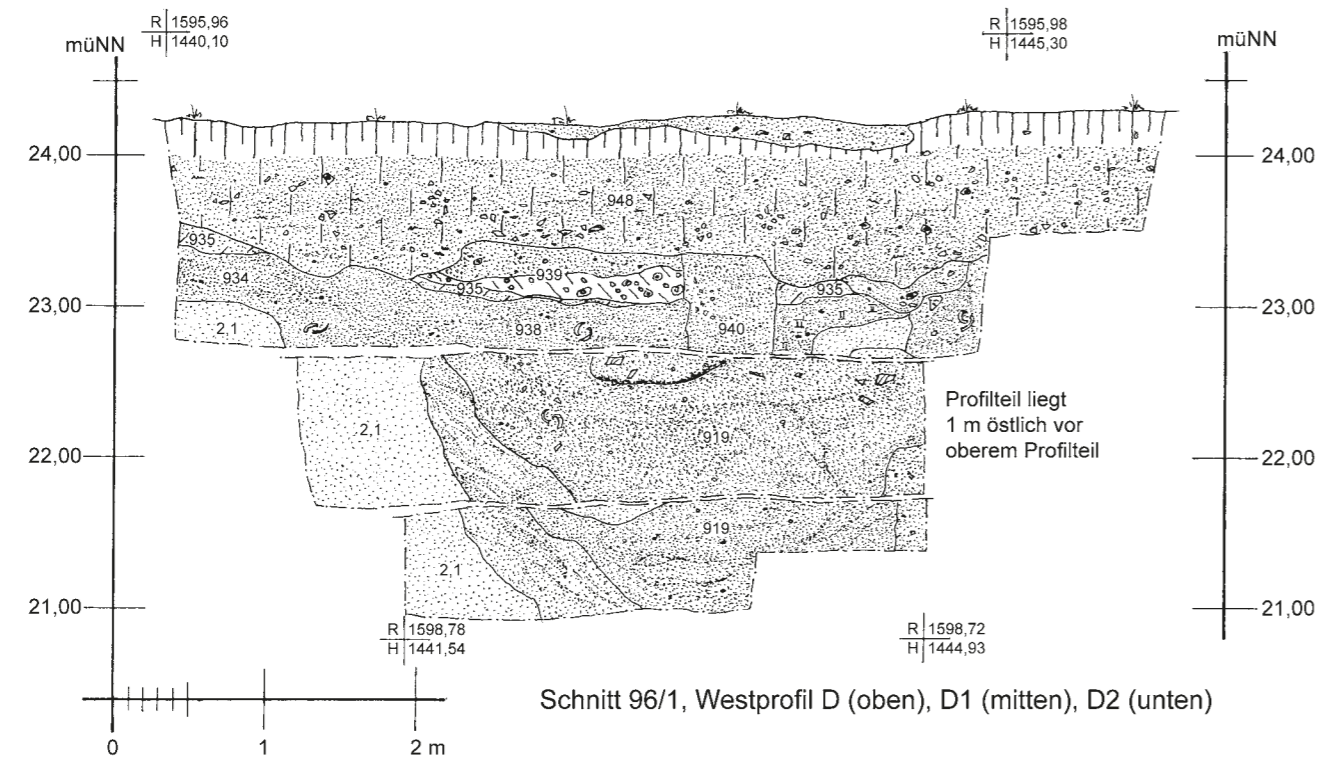

Profil 41

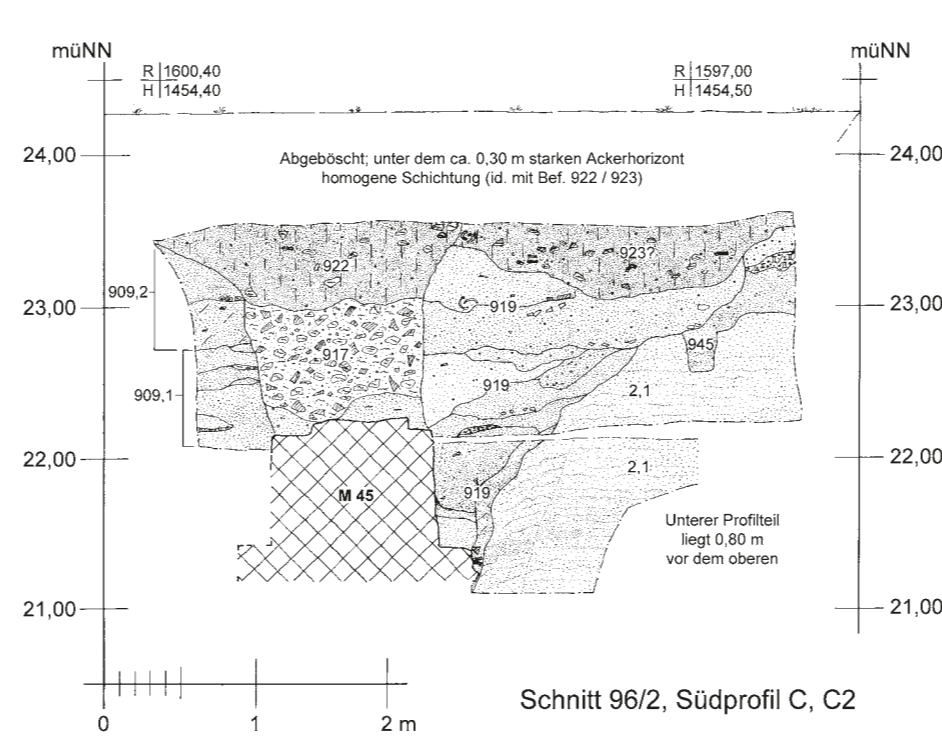

Profil 42

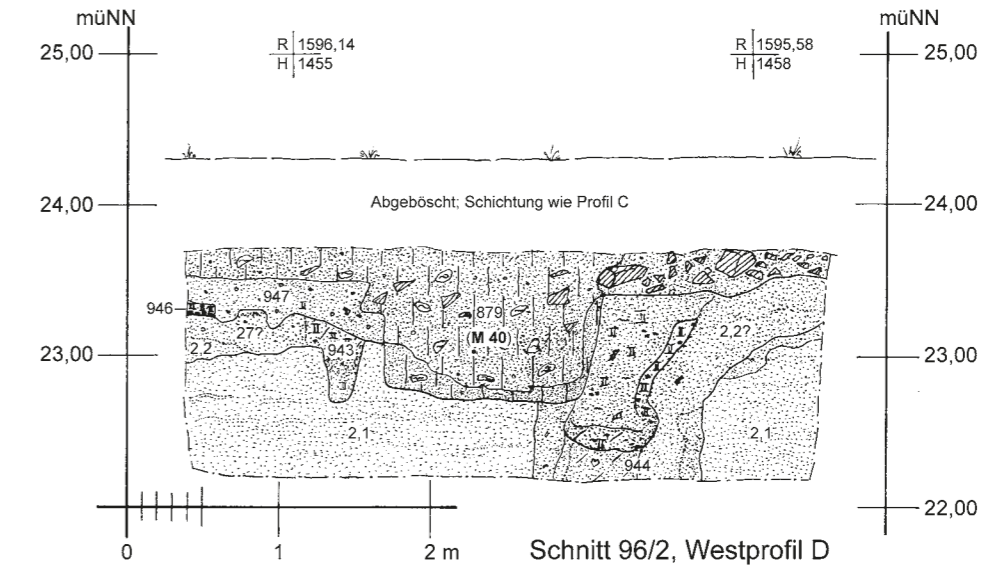

Profil 43,2

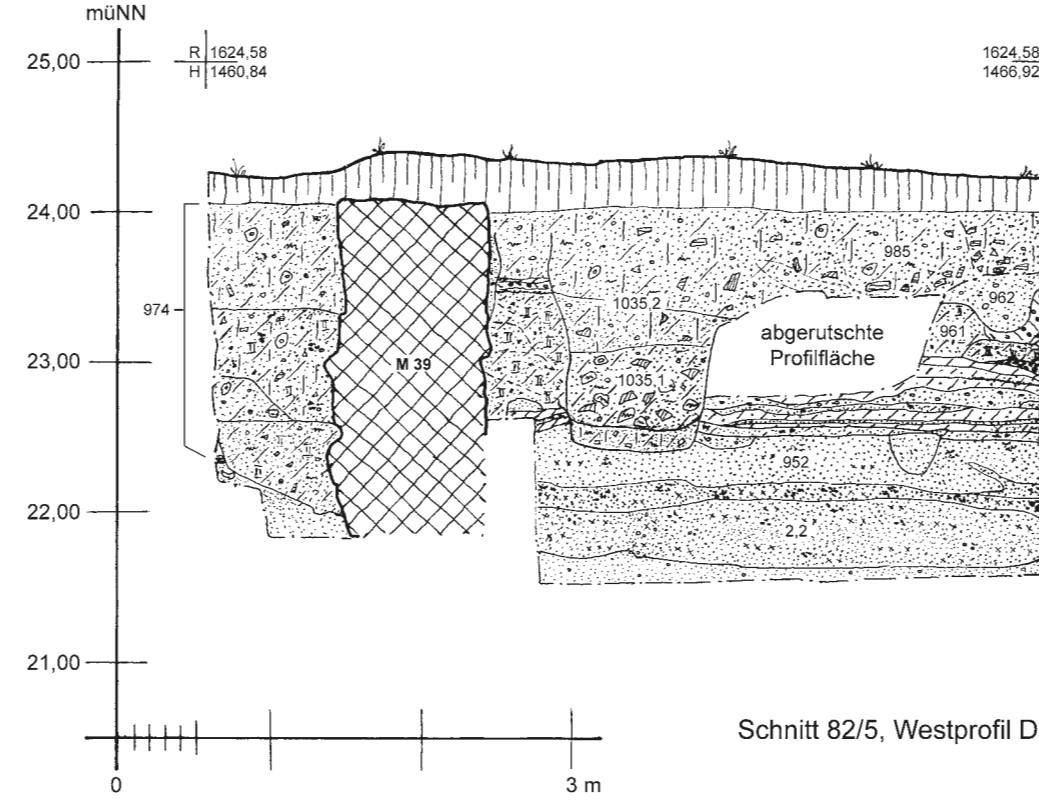

Profil 43,1

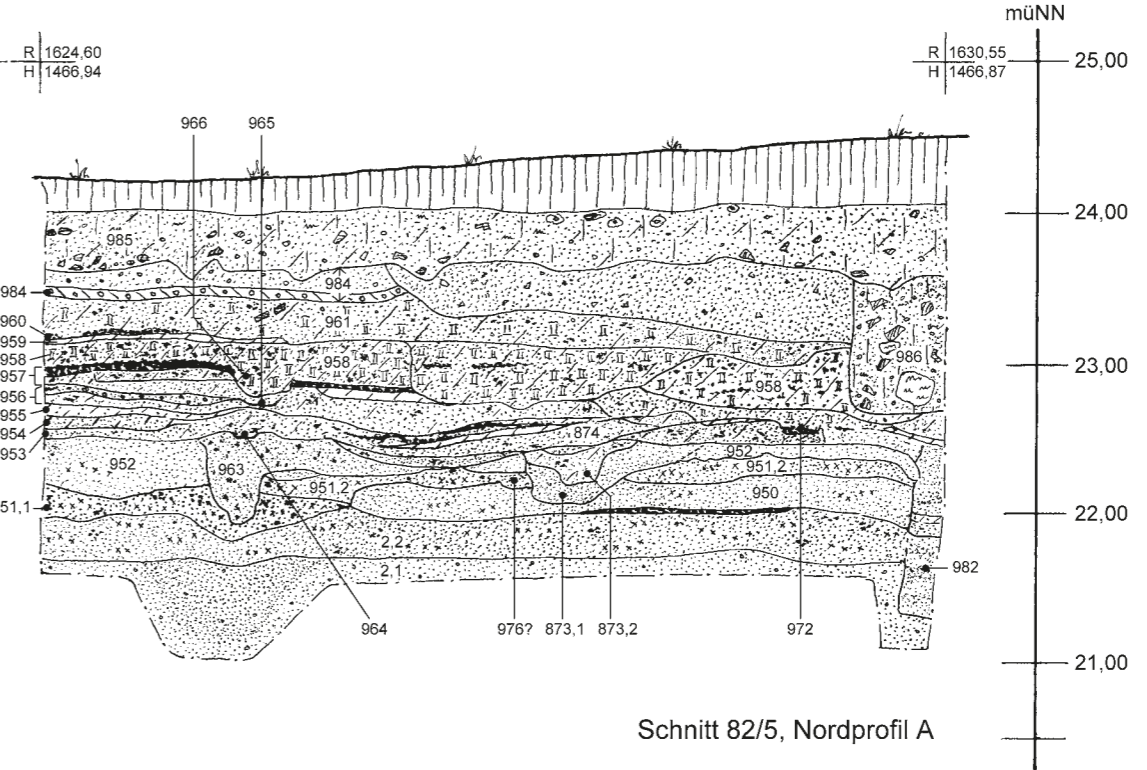

Profil 44,2

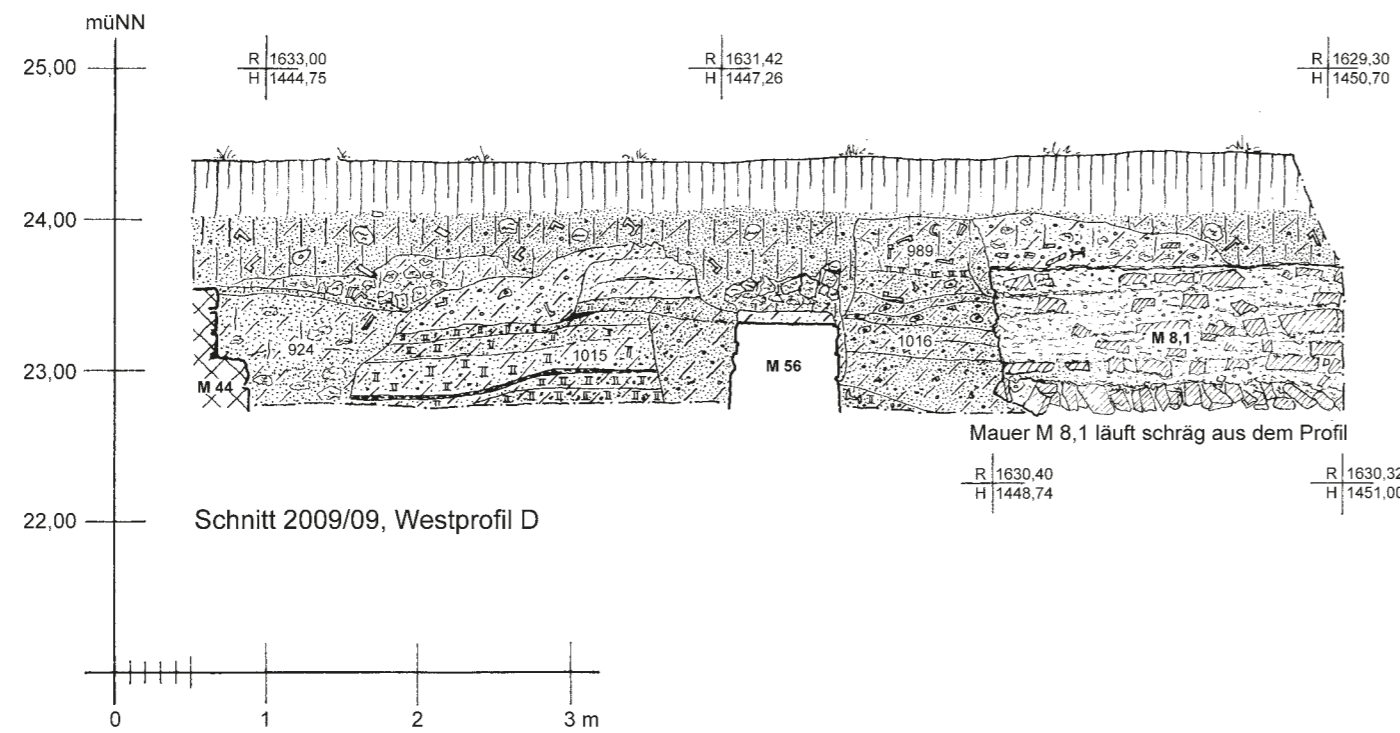

Profil 44,1

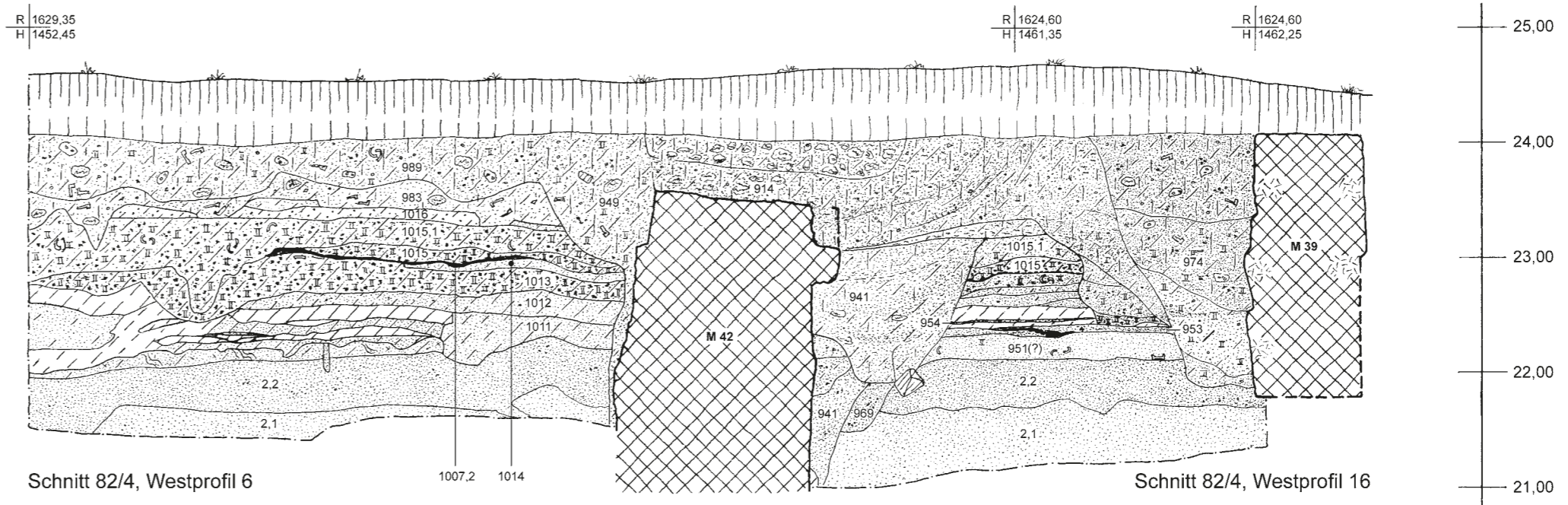

Profil 45

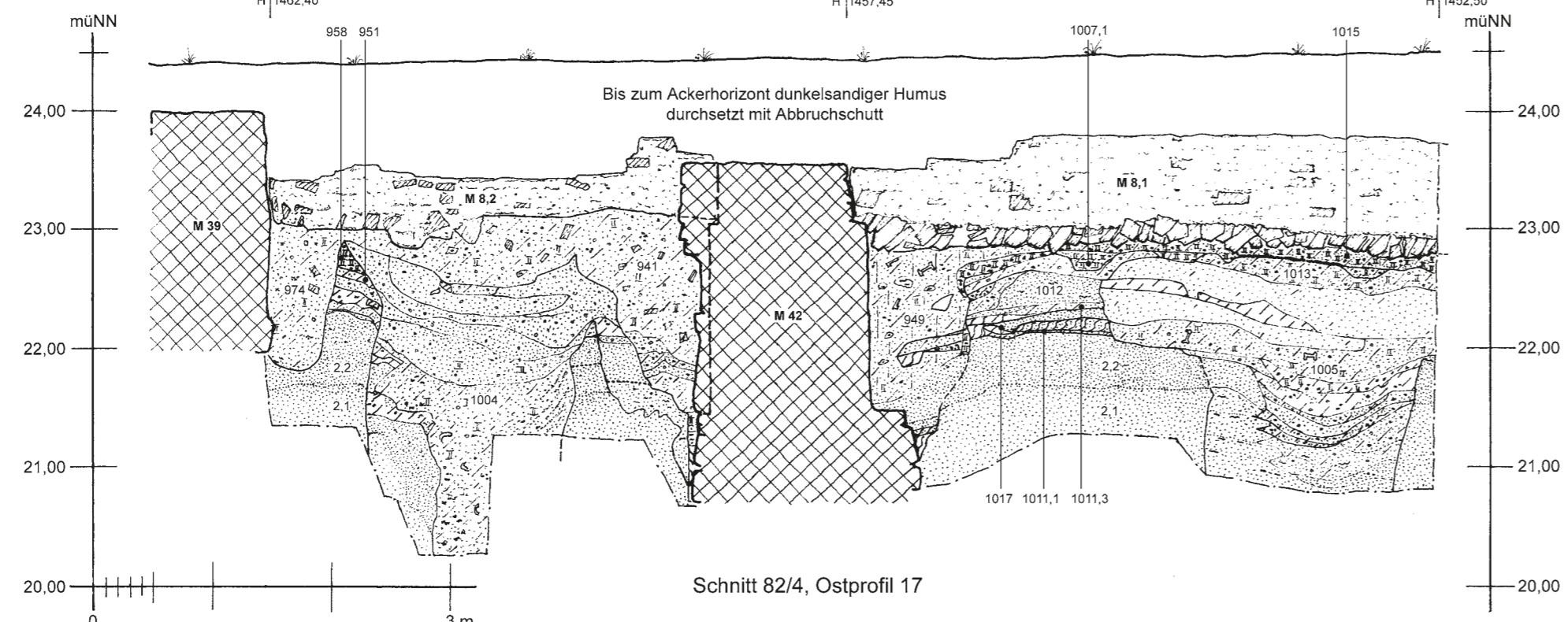

Profil 46

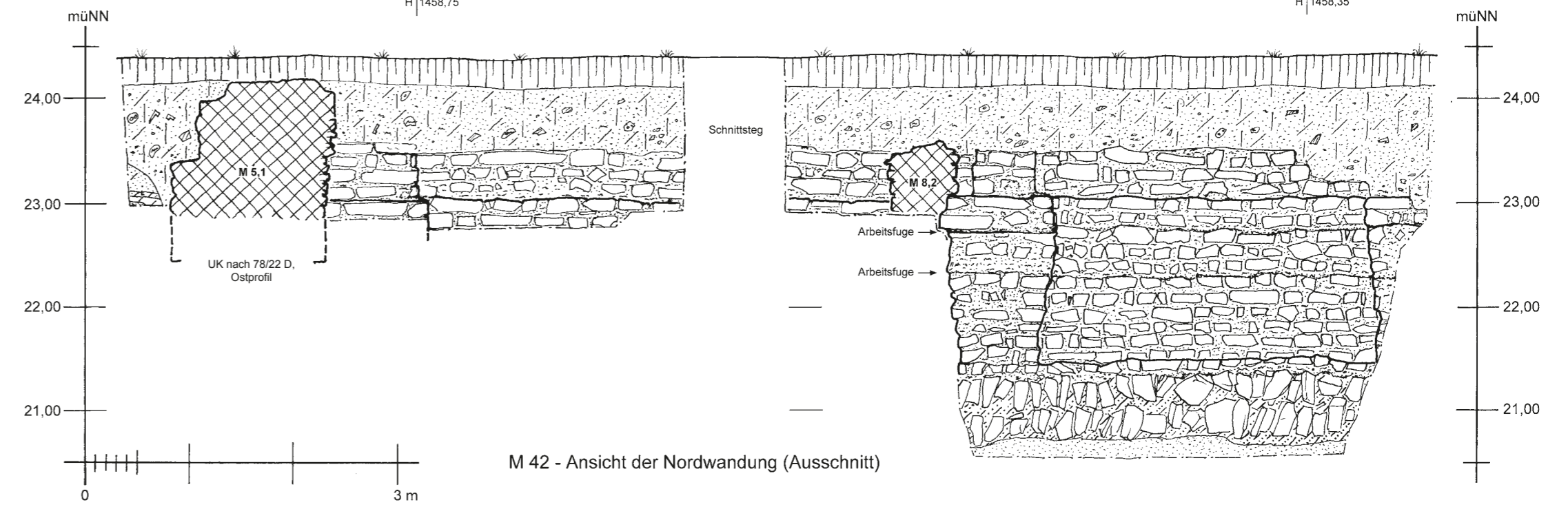

Profil 47

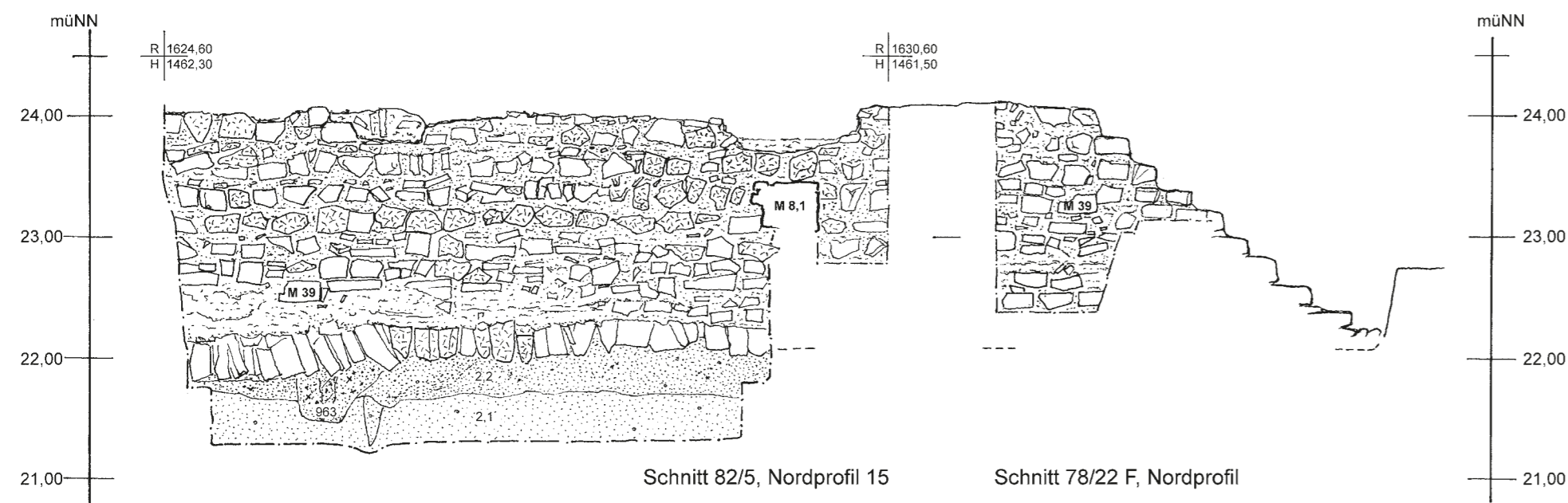

Profil 48

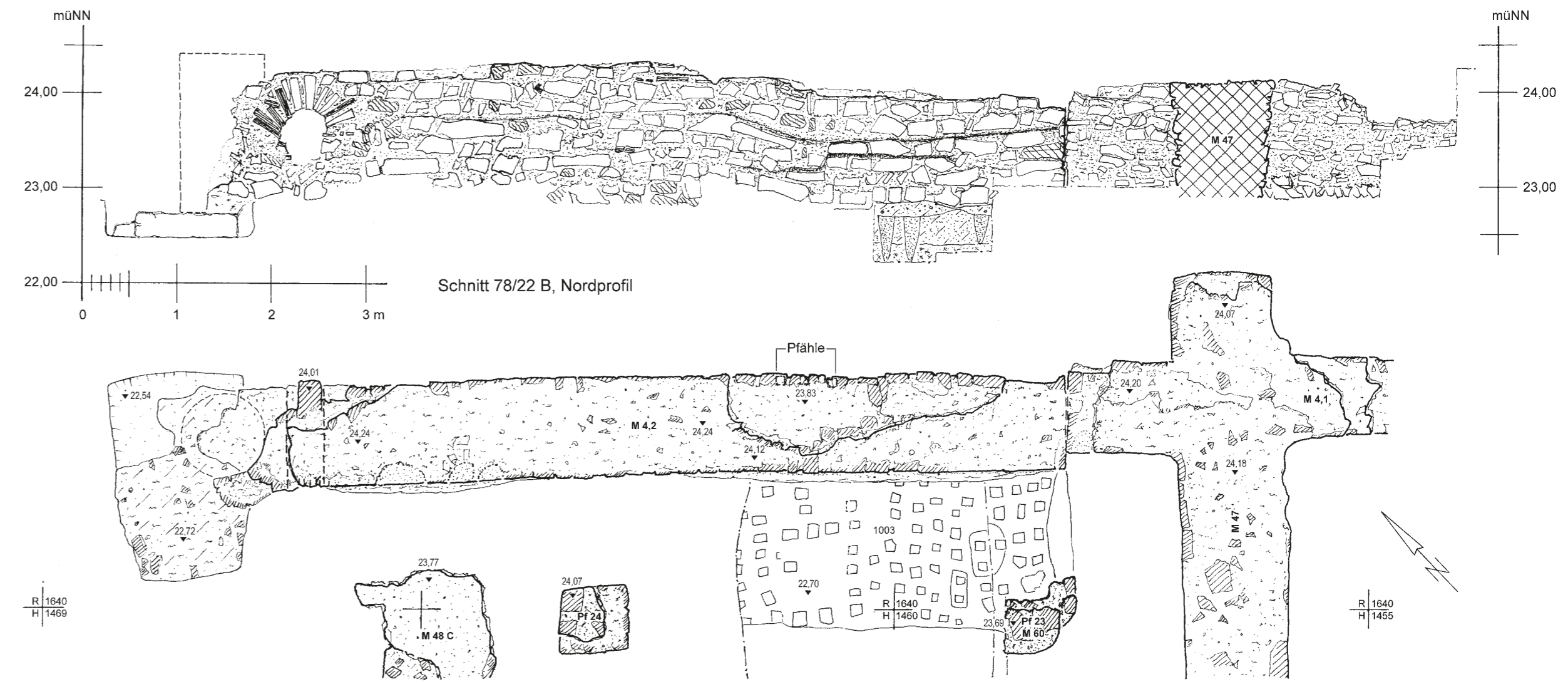

Profil 49

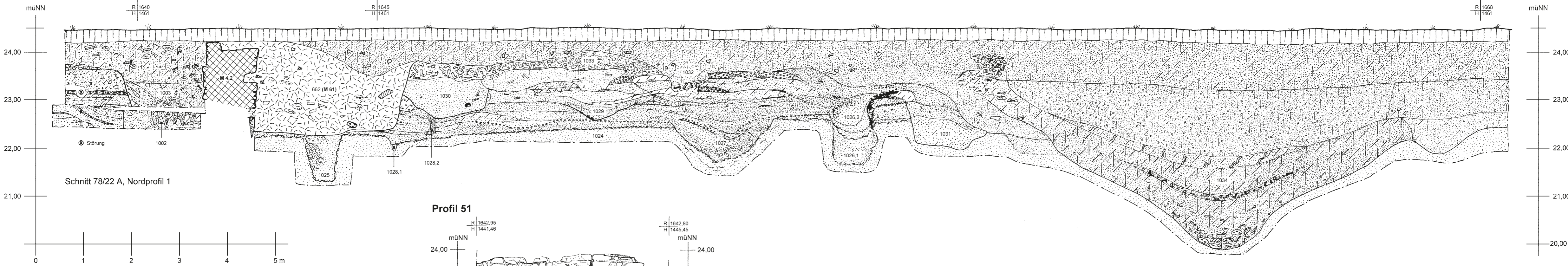

Profil 51

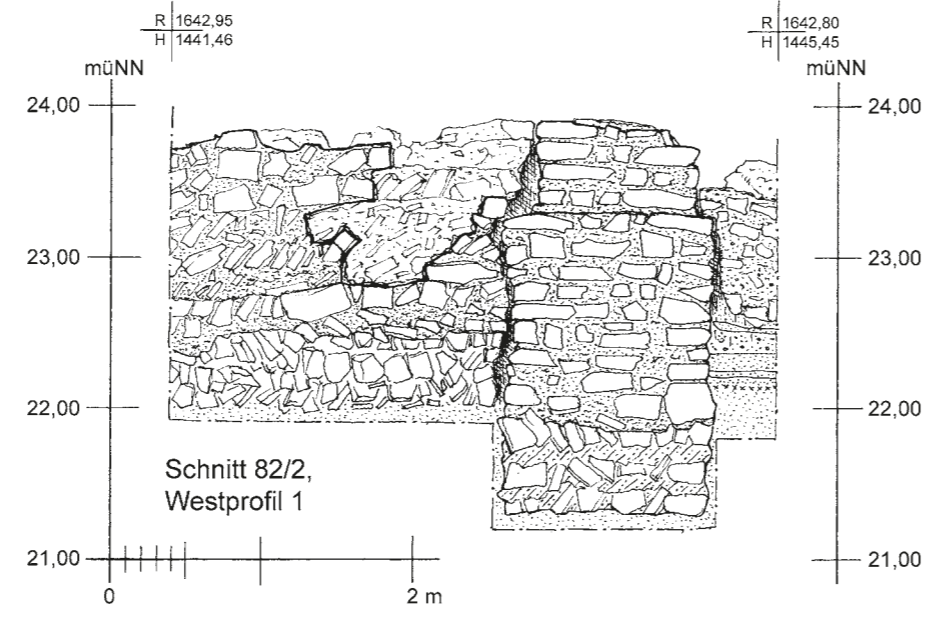

Profil 50

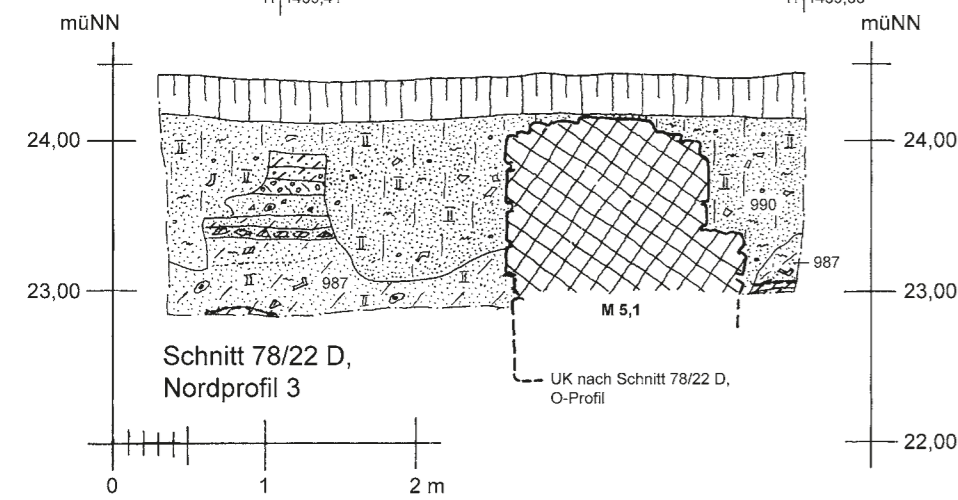

Profil 52

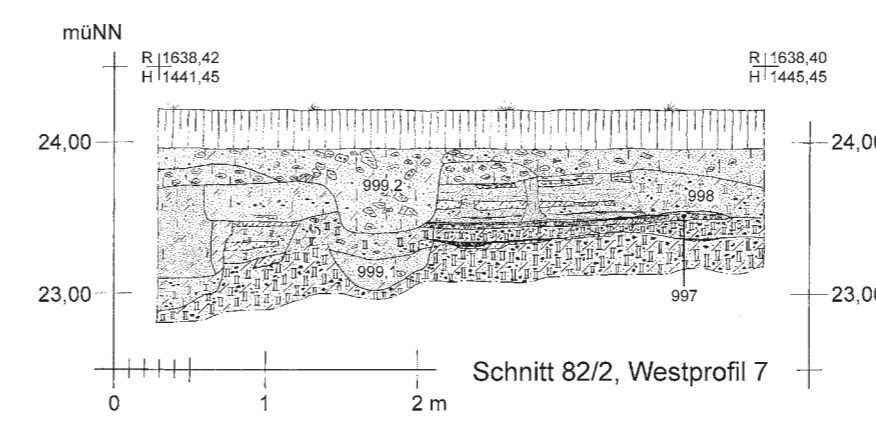

Profil 53

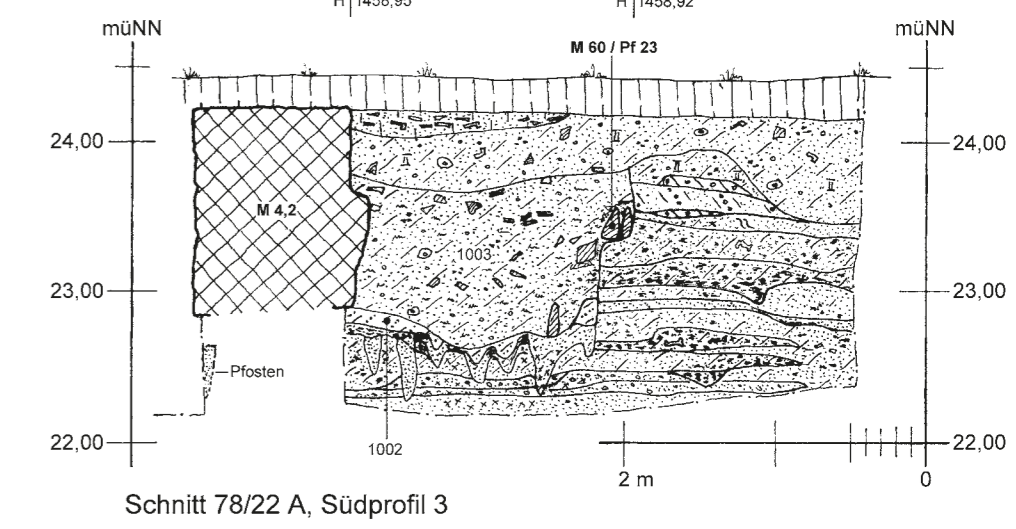

Profil 54

